

# LLD Manual

Revision 003, Januar 2007  
Revision 003, Januar 2007

You are advised to carefully read this User Manual before powering on the LLD laser distance measuring module for the first time. This is necessary to ensure that you will be able to utilize all the capabilities and features which your new acquisition provides. This technology is subject to continuously ongoing development.

Editorial deadline: January 2007

Document number: 012840-007-98-02-0107

WayCon Positionsmesstechnik GmbH  
Mehlbeerenstr. 4  
82024 Taufkirchen, Germany  
Tel.: +49 89 67 97 13-0  
Fax: +49 89 67 97 13-250  
E-Mail: info@waycon.de  
Revisionsstand

## CE

### **Note:**

No part of this User Manual may be reproduced in any way (by photographing, photocopying, microfilm or any other technique) without prior written approval by WAYCON Laser, Optik, Systeme GmbH, nor may it be processed, duplicated or disseminated with the help of electronic systems.

Proper care has been used in compiling this document. No liability will be accepted in the event of damage resulting from failure to comply with the information contained herein.

## Dear User

For highlighting purposes, the following pictogram, signs of reference and warning symbols are used throughout this Manual:

Warning and reference symbols

- Enumeration
-  Advice/Important/Important Note
- Reference (to a passage of text or a Figure)

## Warning symbols



**Warning:** Indicates potential health risks that may occur if symbols of this type are disregarded.



**Caution:** Warns of potential product damage.



**Laser:** Warns of potential exposure to emerging visible or invisible laser radiation.



**Information:** Provides a reference to important data or details.

## Content

1 General	5
2 Safety Instructions	6
2.1 Basic Notes	6
2.2 Intent & Conforming Use	6
2.3 Nonconforming Use	6
2.4 Laser Classification	7
2.5 Electrical Supply	7
2.6 Important Operating Advice	7
3 Technical Data	8
3.1 Scope of delivery	8
3.2 Laser	8
3.3 Measuring Performance	8
3.4 Interface	9
3.5 Environment & Ambient Conditions	10
3.6 Mechanical Mounting Conditions	10
3.7 Electrical Mounting Conditions	12
3.8 Interface Cable	13
4 Communications Protocol	14
4.1 Example: Establishing Communication with Hyperterminal	15
4.2 Online Help	18
4.3 Commands and their functions	19
4.3.1 DT.....distancetracking	19
4.3.2 DS.....distancetracking 7 m	19
4.3.3 DW.....distancetracking with cooperative target (10Hz)	20
4.3.4 DX.....distancetracking with cooperative target (50Hz)	20
4.3.5 DF.....distance measurement with external trigger	20
4.3.6 DM.....distance measurement	20
4.3.7 TP.....internal temperature [C]	21
4.3.8 SAx.....display/set average value [1..20]	21
4.3.9 SDd.....display/set display format [d/h]	21
4.3.10 STx.....display/set measure time [0..25]	21
4.3.11 SFx .x.....display/set scale factor	22
4.3.12 SEx.....display/set error mode [0/1/2]	23
4.3.13 ACx.x.....display/set ALARM center	23
4.3.14 AHx.x.....display/set ALARM hysteresis	23
4.3.15 AWx.x.....display/set ALARM width	24
4.3.16 RB.....display/set distance of Iout=4mA	24
4.3.17 RE.....display/set distance of Iout=20mA	24
4.3.18 RMx y.y z.....remove measurement	24
4.3.19 TDx y.....display/set trigger delay [0..9999ms] trigger level [0/1]	25
4.3.20 TMx y.....display/set trigger mode [0/1] trigger level [0/1]	26
4.3.21 BRx.....display/set baud rate [2400..38400]	27
4.3.22 ASd.....display/set autostart command [DT/DW/DX/DF/DM/TP/LO]	27
4.3.23 OFx.x.....display/set distance offset	27



## Content

4.2.24 SO.....set current distance to offset (offset = - distance)	28
4.2.25 LO.....laser on	28
4.2.26 LF.....laser off	28
4.2.27 PA.....display settings	28
4.2.28 PR.....reset settings	28
5 Operating Modes	29
5.1 RS232	29
5.2 RS422	30
5.3 Digital Switching Output	30
5.4 Analog Output	31
5.5 Trigger Input	33
6 Error Messages	33
7 Service & Maintenance	35

## General

### 1 General

The LLD is a laser range finder to measure distances from 0.1 m to more than 150 m with pinpoint accuracy.

A given target can be clearly identified with the help of a red laser sighting point. In terms of operating reach, the LLD performs depending on the reflectance, morphology and qualities of the target to be measured. The range finder works based on comparative phase measurement. It emits modulated high-frequency light which is diffusely reflected back from the target with a certain shift in phase to be compared with a reference signal. From the amount of phase shift, a required distance can then be determined with millimeter accuracy.

A distance measuring cycle can be triggered in three different ways:

- By sending a command from the PC or another equivalent control unit
- By making appropriate prior parameter settings for the autostart command and applying supply voltage
- By external triggering (in remote-trigger mode)
- Using the autostart trigger function.

For a more detailed description of these three trigger options, you should consult section 5. Operating Modes of this User Manual.

Special performance features are:

- Provides high accuracy and great reach under extreme outdoor temperatures.
- Works in a wide range of operating voltages from 10 V<sub>=</sub> to 30 V<sub>=</sub> from an onboard vehicle supply point, an industrial direct voltage supply net or a DC power pack.
- Features consistently low power consumption of <1.5 W (without I<sub>Alarm</sub>).
- Up to 30 m reach for distance measurement, with potential for more than 150 m reach if additional reflectors are mounted onto the target (depending on reflectance and environmental conditions).
- Visible laser beam for easier sighting.
- RS232 interface port for input of measuring functions and commands from, and output of measured values to, a PC or a laptop.
- Switching output and analog output are separately programmed.
- Switching output with adjustable limit to indicate positive and negative excursion of preselectable distance range window by sighting distance.
- Measured values can be displayed in meters, decimeters, centimeters, feet, inches due to.
- Option for remote triggering of a measurement from an external trigger device.

The LLD measuring module is shipped in a rugged cardboard box with adequate padding for safe transportation.

## 2 Safety Instructions

### 2.1 Basic Notes

These safety and operating instructions should be carefully read and followed during practical work with the LLD.

**There is danger of laser radiation or electrical shock. For necessary repair work, the LLD may not be opened by anyone other than Manufacturer personnel. Unauthorized intervention into the inner product space will void any warranty claims.**



Compliance with all specified operating conditions is necessary. Failure to observe advisory notes or information contained in this Manual or nonconforming product usage may cause physical injury to the user or material damage to the LLD.

Cable connectors must not be plugged or unplugged, as long as voltage is supplied. Remember to turn voltage supply off before you begin working on cable connections.

### 2.2 Intended & Conforming Use

- Measurement of distances
- Special measuring functions
- Compliance with prescribed temperatures for operation and storage
- Operation at correct voltage level
- Application of specified signal levels to the appropriate data lines.

### 2.3 Nonconforming Use

- Do not operate the LLD in any other way than described under “Intended & Conforming Use“ above and only in a proper working condition.
- Safety devices must not be defeated or otherwise rendered ineffective.
- Information and warning signs must not be removed.
- Repair work on the LLD must not be carried out by anyone other than WAYCON personnel.
- Refrain from using the LLD in an explosive environment.
- Measurement with the LLD pointed at the sun or other strong light sources may produce faulty results.
- Measurement of targets with poor surface reflectance in a strongly reflecting environment may also result in faulty measurement values.
- Measurement of strongly reflecting surfaces may deliver faulty results.
- Measurement performed through transparent optical media, for example, glass, optical filters, plexiglass, etc. may equally produce incorrect results.
- Rapidly changing measuring conditions are likely to falsify the result of measurement.

## 2.4 Laser Classification



The LLD is a class 2 laser product as stipulated in IEC825-1/DIN EN 60825-1:2001-11 and a class II product under FDA21 CFR. In the event of accidental, short-time laser exposure, the human eye is sufficiently protected by its own optico-facial winking reflex. This natural reflex may be impaired by medication, alcohol and drugs. Although the product can be operated without taking special safety precautions, one should refrain from directly looking into the laser beam. Do not direct the laser beam onto persons.



**Caution:**  
There is class 2 laser radiation. Do not look into the beam!

## 2.5 Electric Supply



Use only 10 V to 30 V direct voltage for LLD operation. Use only the specially designated connector terminal for voltage supply. Specified signal levels must not be exceeded, in order to guarantee correct data communication.

## 2.6 Important Operating Advice

To make full use of the system's inherent performance capabilities and achieve a long service life, you should always follow these operating rules:

- Do not turn the module on if there is fogging or soiling on its optical parts!
- Do not touch any of the module's optical parts with bare hands!
- Proceed with care when removing dust or contamination from optical surfaces!
- Prevent exposure to shock impacts during transportation of the LLD!
- Prevent overheating of the LLD!
- Prevent major temperature variances during LLD operation.
- In accordance with IP65 internal protection standards, the LLD is designed to be splashproof and dustproof.



Read these safety and operating instructions with due care and follow them in practical use.

## 3 Technical Data

### 3.1 Scope of delivery

#### Description

LLD-150-RS232

LLD-150-RS422

LLD-150-RS232-50 Hz

LLD-150-RS422-50 Hz

#### Optional accessories

#### Description

Power chord, 2 m

Power chord, 5 m

Power chord, 10 m

12-pol jack (female)

Set of Customer documentation (hardcopy)

### 3.2 Laser

Laser:	650 nm laser diode; red light
Laser class:	650 nm, visible, laser class 2, conforming to standard IEC825-1/EN60825, class II (FDA21 CFR)
Output power:	< 1mW
Laser divergence:	0.6 mrad
Beam diameter:	< 6 mm at 10 m distance < 30 mm at 50 m distance < 60 mm at 100 m distance

### 3.3 Measuring Performance

Measuring range:	0.1 m to 30 m for natural, diffusely reflecting surfaces (for DT, DF or DM and ST =0), and up to 150 m with a target board
accuracy:	Measuring ± 2 mm for white surfaces, (+15 °C ... +30 °C) ± 3 mm for natural surfaces, (+15 °C ... +30 °C) ± 4 mm at 0.1 ... 0.5 m range in DS mode, (+15 °C ... +30 °C) ± 5 mm (-10 °C ... +50 °C)
Measured value resolution:	Depends on scale factor (1 mm with SF = 1)
Time to measure:	typ. 160 ms ... 6s in standard mode measuring any type of surface 100 ms in "DW" measuring mode 20 ms in "DX" measuring mode (only LLD42)

conditional on target reflectance, ambient light influences and atmospheric conditions

Max. target motion speed: 4 m/s in "DX" measuring mode (only LLD42)  
Max. acceleration: 2.5 m/s<sup>2</sup> in "DX" measuring mode (only LLD42)

### 3.4 Interface

Type of connection: 12-pole M18 flange-mount connector (Binder series 723)

Supply voltage (U<sub>v</sub>): DC 10 V ... 30 V

Max. power consumption  
(in no-load state): < 1,5 W

Data interface: RS232 / RS422

(Please specify on  
ordering sheet!)

Baud rate: 9.6 kBaud (2.4/4.8/19.2/38.4 kBaud selectable)

Digital switching  
output: Open collector HIGH = U<sub>v</sub> - 2 V, LOW < 2 V,  
rated for loads up to 0.5 A, with switching threshold, latitude  
(width) and hysteresis selectable

Analog output: 4 mA ... 20 mA, distance range limits can be set, behavior on  
error report can be preselected, 3 mA or 21 mA  
Load resistance: ≤ 500 Ω against GND  
Accuracy: ± 0.15 %  
Max. temperature drift: 50 ppm/K

Trigger input: Trigger voltage 3 V ... 24 V  
Trigger threshold + 1.5 V,  
Trigger delay 5 ms + selectable delay time until  
start of measurement  
Trigger pulse length ≥ 1 ms  
Delay time (trigger delay) selectable from 0 ms to 9999 ms  
Extended trigger function selectable autostart trigger

Max. input  
voltages: U<sub>v</sub> = 30 V (protected against polarity reversal)  
RxD = ± 25 V  
RX+, RX- = ± 14 V  
TRIG = - 25 V

Output voltages: TxD ≥ 5 V  
TX ± 2 V, 2 x 50 W load differential  
ALARM U<sub>v</sub> - 2

### 3.5 Environment & Ambient Conditions

Operating temperature: - 10 °C ... + 50 °C  
 Storage temperature: - 20 °C ... + 70 °C  
 Protection type: IP65

### 3.6 Mechanical Mounting Conditions

Casing: Extruded aluminum profile with powder-coat paint finish, front-side & rear-side cover and tube anodized

Dimensions (L x W x H): 182 mm x 96 mm x 50 mm  
 Weight: 850 g

The casing consists of a rugged, corrosion-resistant extruded aluminum profile with front-side and rear-side covers also in corrosion-resistant design. Four mounting holes are provided in the baseplate for mechanical attachment of the LLD ( Figure 1: Dimensional drawing).

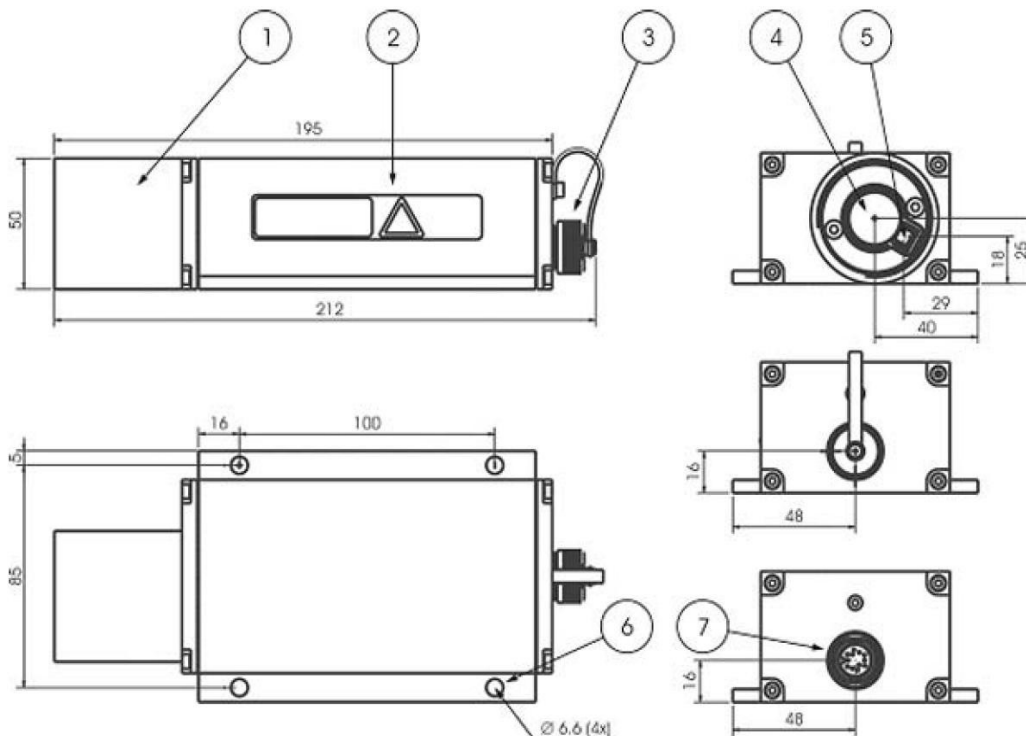

Figure 1: Dimensional drawing

- 1 Equalizer tube at front cover
- 2 Casing
- 3 Protective cap for flange-mount connector
- 4 Receiver optics
- 5 Sender optics
- 6 Mechanical mounting holes (four)
- 7 12-pole M18 flange-mount connector (Binder series 723)

To protect the range finder's optical surfaces from dust, physical contact, mechanical impacts, etc., the casing has a special equalizer tube attached to it. This tube can be extended or removed, as necessary to meet the customer's operating needs. Please note that measurement cannot be guaranteed to function correctly if the equalizer tube is removed by unqualified action!

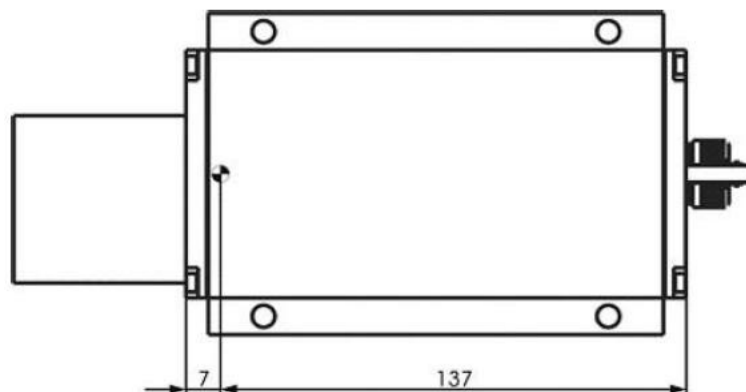

Figure 2: Offset against zero-edge

The LLD's zero-point is located 7 mm behind the outer surface of the front cover or 137 mm before the back cover outside face respectively. This zero-point has been introduced for constructional design reasons. It can be compensated with the help of parameter "OF" (see section 4.3.19 „OF.....display/set distance offset“).

### 3.7 Electrical Mounting Conditions

Located on the back cover is a connector terminal. A 12-pole round-type (flangemount) series 723 connector from Binder has been selected for this purpose. It is sealed against the casing to comply with IP 65 requirements. This connector type guarantees optimized screening and a high IP degree. The required counterpart is a cable jack (series 423 from Binder) with grading ring. A cable set with open ends is optionally available.

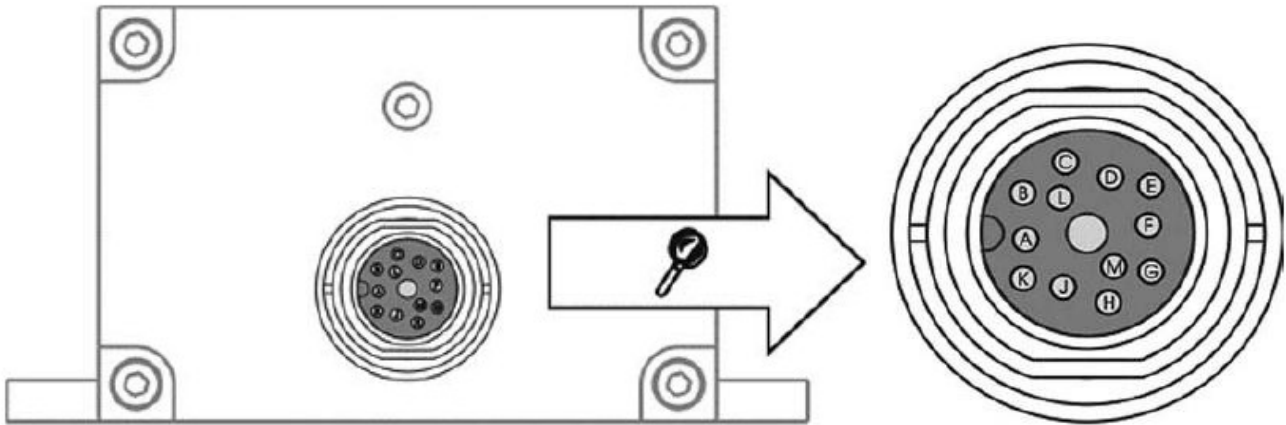

Figure 3: View of LLD pole assignments

Pin	Interfacecable		LLD41		LLD42
A	Green		TxD RS232- send data		RX+ RS422- receive data+
B	Yellow		RxD RS232- receive data		RX- RS422- receive data -
C	Brown		TRIG External trigger input		TRIG External trigger input
D	Red	I <sub>OUT</sub>	Analog output	I <sub>OUT</sub>	Analog output
E	Black	n.c.			TX- RS422-send data -
F	Violet	n.c.			TX+ RS422-send data +
G	Orange	U <sub>v</sub>	Supply voltage	U <sub>v</sub>	Supply voltage
H	White	ALARM	Digital switching output	ALARM	Digital switching output
J	Gray	GND	GND	GND	GND
K	-	n.c.			n.c.
L	Blue	GND	GND	GND	GND
M	-	n.c.			n.c.

Table 2: Pinout assignments

GND wires are connected to an internal collective ground point. They provide the reference potential for all voltage values quoted below. If input signals are applied to an output port, this may damage the LLD! For data communication via RS232, you are recommended to use cable 4 (gray, GND) for signal ground and cable 7 (blue, GND) for supply ground! The limiting values of voltages, load rates and logic levels are in accordance with RS232 and RS422 standard requirements. All outputs are protected against steady short-circuit currents.

### 3.8 Interface Cable

**Caution:**

**Both cable ends are exposed! The user is responsible to take precautions that will prevent any kind of shorts!**



For interface cable wire assignments, refer to Table 2. The interface cable can be provided in 2 m, 5 m and 10 m length version. Customized cable lengths are optionally available by previous agreement with WAYCON Laser, Optik, Systeme GmbH.



Figure 4: Interface-Kabel

Interface cable extension is possible. One should, however, observe some important rules, depending on the particular application scenario:

### LLD

RxD and TxD data lines should be kept as short as possible in all cases, because they tend to have an interference emitting and interference receiving effect, notably, when in open state. Especially in environments with strong spurious radiation there may be faults that may in some cases require a reset (turning the LLD off and on again). In cases where no RS232 interface communication is required after parameterization, you should provide for a termination wiring as shown in Figure 5.

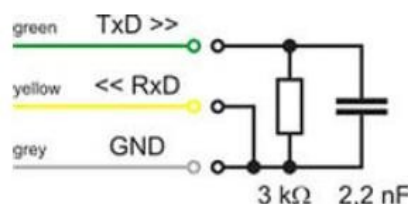

Figure 5: Recommended termination wiring for work with open RS232

## LLD 50Hz

Extension and termination according to standard requirements.

For correct screening, three essential rules must be followed:

1. Use screened cable, e.g. "10XAWG224CULSW", remember to extend also the cable screen!
2. Connect screen to reference potential of UV on cable end.
3. For integration with vehicles:  
Where attachment point and reference potential (GND or "-") have equal potentials, it may be necessary to electrically isolate the LLD casing, in order to prevent ground loops.

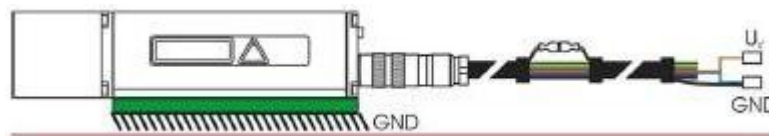

Figure 6: Correct screening of LLD

## 4 Communications Protocol

The following is a short overview of the communications protocol

### Command Description

DT Starts distance tracking

DS Starts distance tracking 7 m

DW Starts distance tracking on white target at 10 Hz

DX Starts distance tracking on white target at 50 Hz (only LLD42)

DF Starts remote-triggered single distance measurement (single shot)

DM Starts single distance measurement (single shot)

TP Queries inner temperature

SA Queries /sets floating average value (1...20)

SD Queries /sets output format (dec/hex)

ST Queries /sets time to measure (0...25)

SF Queries /sets scale factor

SE Queries /sets error mode (0, 1, 2)

AC Queries /sets alarm center

AH Queries /sets alarm hysteresis

AW Queries /sets alarm width

RB Queries /sets beginning of range (4 mA)

RE Queries /sets end of range (20 mA)

RM Queries /sets removal of measured value

TD Queries /sets trigger delay

TD Queries /sets trigger mode

BR Queries /sets baud rate

AS Queries /sets autostart

- OF Queries /sets offset
- SO Sets current distance as offset
- LO Turns laser on
- LF Turns laser off
- PA Displays all parameter values
- PR Resets all parameters to standard values

Table 3: Short overview of communications protocol

## 4.1 Example: Establishing Communication with Hyperterminal

Hyperterminal is a terminal program that is typically included in Win32 operating system delivery.

To start Hyperterminal, use the starting menu in this order:

Start → Programs → Accessories → Communication → Hyperterminal

Initially, a dialog box appears for defining a randomly selectable name of a communication session you want to begin.

## Communications Protocol



Figure 7: Establishing communication with the hyperterminal: name of communication session

A second dialog box allows you to select the serial COM port to which the LLD is connected.



Figure 8: Establishing communication with the hyperterminal: COM port selection

A third dialog box is then displayed with various parameter setting options for this communication session. At this point in the process, the baud rate (bits per second) and the flow control must be correctly initialized.

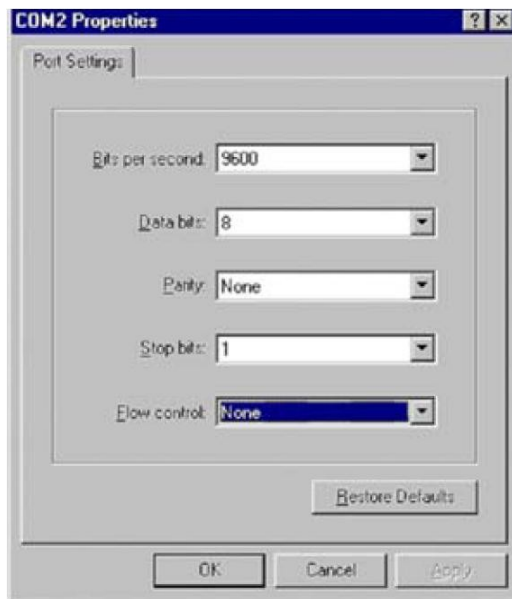

Figure 9: Establishing communication with the hyperterminal: communication parameter settings

A third dialog box is then displayed with various parameter setting options for this communication session. At this point in the process, the baud rate (bits per second) and the flow control must be correctly initialized.

## Note:

A currently entered command will only be displayed if "Local echo" is enabled. This function can be accessed via File menu

File → Properties → "Settings" tag → ASCII Setup.

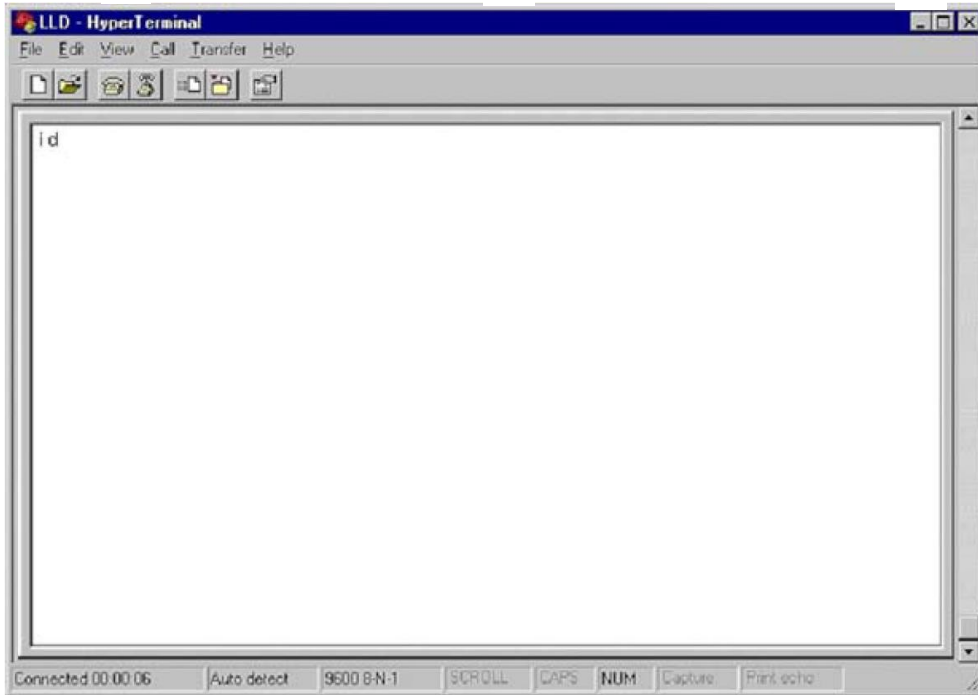

Figure 10: Establishing communication with the hyperterminal: ID input

Once this command has been triggered by pressing the Enter key, the LLD should display its online help in response.

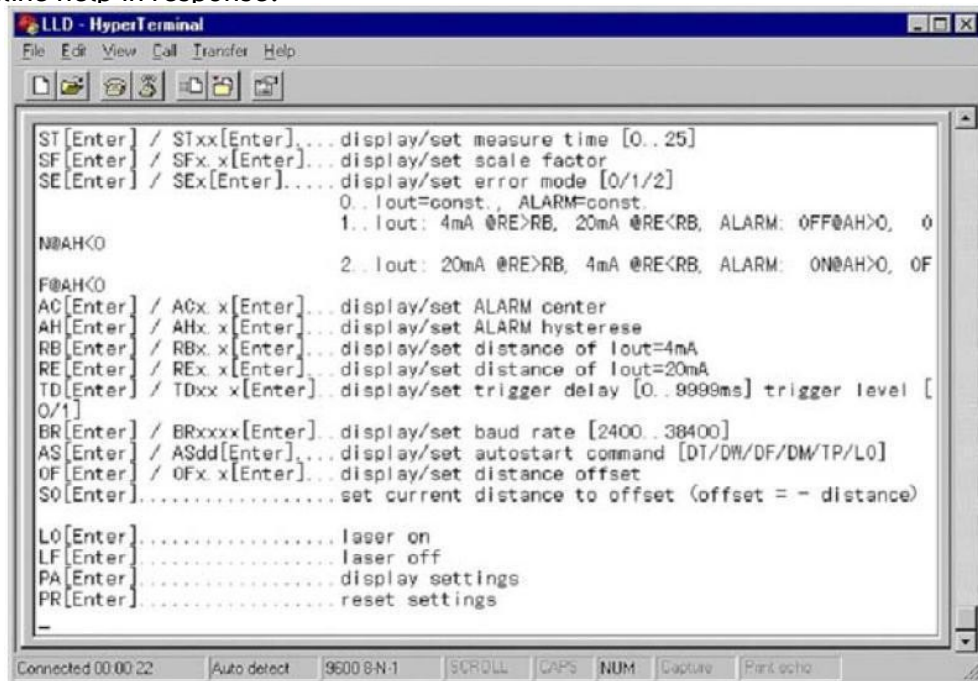

Figure 11: Establishing communication with the hyperterminal: LLD response

Before terminating a hyperterminal session, the software queries if you really want communication abandoned. This query must be acknowledged.



Figure 12: Establishing communication with the hyperterminal: disconnect query box

Finally (unless performed earlier), the current hyperterminal configuration can be saved for more convenience, i.e. you don't have to reconfigure the interface for each new hyperterminal session.



Figure 13: Establishing communication with the hyperterminal: saving a communication session

## 4.2 Online Help

Once communication has been established with a PC (as described above), an online help tool can be called up by triggering an ID [Enter] or id [Enter] command at the keypad. Its purpose is to support work with distance measurement and parameterization commands. [Enter] corresponds to hexadecimal 0Dh (carriage return)

```

DT[Enter] .....distancetracking
DS[Enter] .....distancetracking 7m
DW[Enter] .....distancetracking with cooperative target (10Hz)
DX[Enter] .....distancetracking with cooperative target (50Hz)
DF[Enter] .....distance measurement with external trigger
DM[Enter] .....distance measurement
TP[Enter] .....internal temperature [C]
SA[Enter] / SAX[Enter] .....display/set average value [1..20]
SD[Enter] / SDD[Enter] .....display/set display format [d/h]
ST[Enter] / STx[Enter] .....display/set measure time [0..25]
SF[Enter] / SFx.x[Enter] .....display/set scale factor
SE[Enter] / SEx[Enter] .....display/set error mode [0/1/2]
                                0..Iout=const., ALARM=const.
                                1..Iout: 3mA @RE>RB, 21mA @RE<RB,
                                ALARM: OFF@AH>0, ON@AH<0
                                2..Iout: 21mA @RE>RB, 3mA @RE<RB,
                                ALARM: ON@AH>0, OFF@AH<0
AC[Enter] / ACx.x[Enter] .....display/set ALARM center
AH[Enter] / AHx.x[Enter] .....display/set ALARM hysteresis
    
```

```
AW[Enter] / AWx.x[Enter].....display/set ALARM width
RB[Enter] / RBx.x[Enter].....display/set distance of Iout=4mA
RE[Enter] / REX.x[Enter].....display/set distance of Iout=20mA
RM[Enter] / RMx y.y z[Enter]..remove measurement
TD[Enter] / TDx y[Enter].....display/set trigger delay [0..9999ms] trigger level
[0/1]
TM[Enter] / TMx y[Enter].....display/set trigger mode [0/1] trigger level [0/1]
BR[Enter] / BRx[Enter].....display/set baud rate [2400..38400]
AS[Enter] / ASd[Enter].....display/set autostart command [DT/DS/DW/DX/DF/DM/
TP/LO/ID]
OF[Enter] / OFx.x[Enter].....display/set distance offset
SO[Enter].....set current distance to offset
(offset = - distance)
LO[Enter].....laser on
LF[Enter].....laser off
PA[Enter].....display settings
PR[Enter].....reset settings
```

## 4.3 Commands and their functions

Command entries are not case-sensitive. This means that small and capital lettering can be used for commands. Any command which is to be sent to the LLD must be terminated by a hexadecimal 0Dh (carriage return) character. Where decimal digits are to be entered, they must be separated by period (2Eh). For command parameter entries, one must distinguish between parameter settings and parameter queries.

Querying is achieved with a command in simple format. e.g. (for alarm center parameters):  
AC[Enter]

For parameter setting, a new value must be added after the command with no delimitation sign in between, for example: AC20.8[Enter]

In the given example, the alarm center will be set to 20.8.

### 4.3.1 DT.....distancetracking

Input parameter SA, SD, SE, SF, ST, OF

Output RS232/RS422, digital switching output, analog output

DT mode can be chosen for distance measurement of different kinds of surfaces (varying reflectance). Working in this mode, the LLD uses internal algorithms to continuously evaluate the quality of laser radiation that is received back. This may cause longer measuring times in the case of varying reflectance or sudden jumps in distance. The minimum time to measure is 160 ms, the maximum time is 6 s. If the measuring signal fails to reach a specified quality within six seconds, an error message is output. The time to measure may also be limited by setting the ST parameter to a desired value.

### 4.3.2 DS .....7m distance tracking

Input parameter SA, SD, SE, SF, ST, OF

Output RS232/RS422, digital switching output, analog output

Operation in **DS** mode makes sense where different types of surfaces have to be measured at close range up to 7 m. Compared to DT measuring mode, it allows a higher measurement rate.

Within the range from 0.1 m to 0.5 m, measuring accuracy is restricted.

Measuring time (time to measure) can be limited via ST parameter settings.

#### **4.3.3 DW.....distance tracking with cooperative target (10Hz)**

Input parameter SA, SD, SE, SF, OF

Output RS232/RS422, digital switching output, analog output

**DW** mode performs at a steady measuring rate of 10 Hz. As a necessary precondition for measured values to be stable, a white target board must be placed at the selected object. There must be no sudden jumps in distance greater than 16 cm within the measuring field!

#### **4.3.4 DX.....distance tracking with cooperative target (50Hz)**

Input parameter SA, SD, SE, SF, OF

Output RS232/RS422, digital switching output, analog output

**DX** mode performs at a steady measuring rate of 50 Hz (only LLD). As a necessary precondition for measured values to be stable, a white target board must be placed at the selected object. This measurement mode is intended in the first place for objects performing homogeneous motion up to 4m/s. For higher rates of measurement, preceding measured values will be included in the process to calculate a currently measured value. There must be no sudden jumps in distance greater than 16 cm within the measuring field!

#### **4.3.5 DF.....distance measurement with external trigger**

Input parameter SD, SE, SF, ST, OF, TD

Output RS232/RS422, digital switching output, analog output

**DF** mode allows a measurement that is triggered by an external trigger pulse. Initially, after selecting this mode, the operator does not receive any response. As soon as the trigger pulse has been detected, the LLD will send data and switches to digital and/or analog output. Settings for trigger delay (delay) and trigger flank can be defined via parameter TD.

(see 4.3.16 TD.....display/set trigger delay [0..9999ms] trigger level [0/1])

#### **4.3.6 DM.....distance measurement**

Input parameter SD, SE, SF, ST, OF

Output RS232/RS422, digital switching output, analog output

**DM** mode triggers a single measurement (single shot).

## 4.3.7 TP.....internal temperature [C]

TP queries the value of the inner LLD temperature.

Note:



In tracking mode, the inner temperature may exceed the surrounding temperature level by as much as 10 K.

## 4.3.8 SAx.....display/set average value [1..20]

Standard setting: 1

SA allows you to calculate a floating average value from 1 to 20 measured values. Calculation is based on this formula. Die Berechnung erfolgt über folgende Formel:

$$\text{Average value } x = \frac{X_1 + X_2 + X_3 + \dots + X_n (20)}{n} \quad \text{with } n = SA$$

## 4.3.9 SDd.....display/set display format [d/h]

Standard setting: d

SD switches between decimal (d) and hexadecimal (h) output format of measured value data. SD affects all commands that output a distance value. A hexadecimal output value is calculated from a given measured distance value (in mm), multiplied by the scale factor SF. Negative distance values are output in two's complement notation.

Example:

Distance = 4.996 m, SF1	dec:	4.996
	hex:	001384 (= 4996 mm × SF1)
Distance = 4.996 m, SF10	dec:	49.960
	hex:	00C328 (= 49960 = 4996 mm × SF10)

## 4.3.10 STx.....display/set measuring time [0..25]

Standard setting: 0

Measuring time is directly conditional on the selected measuring mode. As a general rule, one may say: the poorer the surface reflectance of a selected target, the longer the LLD will take to determine a given distance with specified accuracy. For example, if error message E15 is output because of poor reflectance and insufficient time to measure, this latter setting must be increased.

Available ST value range: 0 to 25

Basically, the greater the time setting is the more time will be available for measurement and the lower the resulting measuring rate. An exception therefrom is zero-value. In this case, the LLD automatically picks the smallest possible time value for measurement! The LLD comes factory-set with ST = 0. ST is effective in the DT, DF and DM mode of operation. The measuring time setting option can also be used to modify the measuring rate, for example, in order to restrict the data volume or for synchronization purposes.

Measuring time can only be set as an approximate value, because the underlying principle of measurement is subject to certain variances that cannot be accounted for:

DT measuring mode → measuring time ≈ ST x 240ms (except ST = 0)

DS measuring mode → measuring time ≈ ST x 150ms (except ST = 0)

### Example:

The target distance is 25 m, but the target's reflectance is not ideal. With a measuring time setting of ST 2, E15 will be output following measurement. The user must increase the time to measure in this case!

### Note:

One should work in DW or DX measuring mode where stable measuring times are required.

### 4.3.11 SFx.x.....display/set scale factor

Standard setting: 1

SF multiplies a calculated distance value with a user-selectable factor for changes in resolution or outputs in a different unit of measure. The scale factor may also be negative.

Scale factor	Resolution	Output	Unit of measure
SF1	1 mm	12.345	m
SF10	0.1 mm	123.45	dm
SF1.0936	0.01 yard	13.500	yard
SF3.28084	0.01 feet	40.501	feet
SF0.3937	1 inch	4.860	100 inch
SF-1	1 mm	-12.345	m

Table 5: Examples of scale factor

## Note:

Following a change in the scale factor, the settings for digital and/ or analog output and offset must be matched accordingly!

### 4.3.12 SEx.....display/set error mode [0/1/2]

Standard setting: 1

SE allows you to configure how the digital switching output (alarm) and/or the analog output is to behave on occurrence of an error message (E15, E16, E17, E18). Depending on the particular LLD41/42 application, different reactions to an error message are possible. Available selection options are 0, 1 and 2 with the following effects in the event of an error message:

SE	Digital switching output (ALARM)	Analog output (I <sub>OUT</sub> )
0	ALARM of latest valid measurement	I <sub>OUT</sub> of latest valid measurement
1	AH: ALARM=LOW -AH: ALARM=HIGH	RE>RB:IOUT=3 mA RE<RB:IOUT=21 mA
2	AH: ALARM=HIGH -AH: ALARM=LOW	RE>RB:IOUT=21 mA RE<RB:IOUT=3 mA

Table 6: Digital switching output and analog output for SE = 0, 1 and 2

### 4.3.13 ACx.x.....display/set ALARM center

Standard setting: 1000

AC sets the beginning of the distance range, for which the switching output will be turned active. The length of this active range can be set using the AW parameter. AC must be selected in keeping with the currently set SF scale factor (refer to section 5.3 Digital switching output).

### 4.3.14 AH.....display/set ALARM hysteresis

Standard setting: +0.1

AH allows you to make parameter settings for the switching hysteresis at the beginning and the end point of the active range of the switching output.

AH must be selected so it is properly matched to the currently valid scale factor (SF).

The mathematical sign of AH can be used to set an active state logic level:

Positive sign (“+”): active range is HIGH-active.

Negative sign (“-“): active range is LOW-active.

No sign setting means positively-signed (refer to section 5.3 Digital switching output).

#### 4.3.15 AWx.x.....display/set ALARM width

Standard setting: 100000

**AW** sets the length of the active range, beginning at AC.

AW settings must be made in agreement with the currently valid SF scale factor.

AW is always equal or greater than "0" (zero).

AW is always equal or greater than |AH| (the amount of AH) (refer to section 5.3

Digital switching output).

#### 4.3.16 RBx.x.....display/set distance of Iout=4mA

Standard setting: 1000

**RB** (Range Beginning) corresponds to the starting point of the distance range that is provided at the analog output.

A distance value = RB will generate a current I<sub>OUT</sub> of 4 mA.

RB must be set in agreement with the currently valid SF scale factor.

RB can be greater or smaller!

Beyond the range that was set via RB and RE, the applied current will be that of the next limiting value. In the event of a fault, the output value will correspond to the current that was set via parameter SE (refer to section 4.3.12) (refer to section 5.4 Analog output).

#### 4.3.17 REx.x.....display/set distance of Iout=20mA

Standard setting: 2000

**RE** (Range End) corresponds to the end point of the distance range that is provided at the analog output. A distance value = RE will generate a current I<sub>OUT</sub> of 20 mA.

RE must be set in agreement of the scale factor SF

RE can be greater or smaller as RB!

Beyond the range that was set via RB and RE, the applied current will be that of the next limiting value. In the event of a fault, the output value will correspond to the current that was set via parameter SE (refer to section 4.3.12) (refer to section 5.4 Analog output).

#### 4.3.18 TD.....display/set trigger delay [0..9999ms] trigger level [0/1]

Standard setting: 0 0 0

**RM** is intended to facilitate settings for a range of expected distance values. Values which are found to be outside of this expected range will be corrected until matching the most recently valid measured values.

RM is only effective in DT mode.

It consists of three parameters which are separated by space (20h).

X designates the number of preceding measured values that will be evaluated in the case of non-conforming measurement. A maximum of ten preceding measured values can be evaluated.

Y defines the range of permissible values. If this range is exceeded in negative or positive direction, the respective measured value will be corrected accordingly.

Z stands for the number of values that are out of the permissible value range (out of tolerance values). In the event of out-of-tolerance values arriving in succession, the most recently corrected value will be included in the correction process for the next out-of-tolerance value. The maximum allowed number of out-of-tolerance values is 100.

**Example:**  $x = 3$   
 $2y = 0.1$   
 $z = 1$

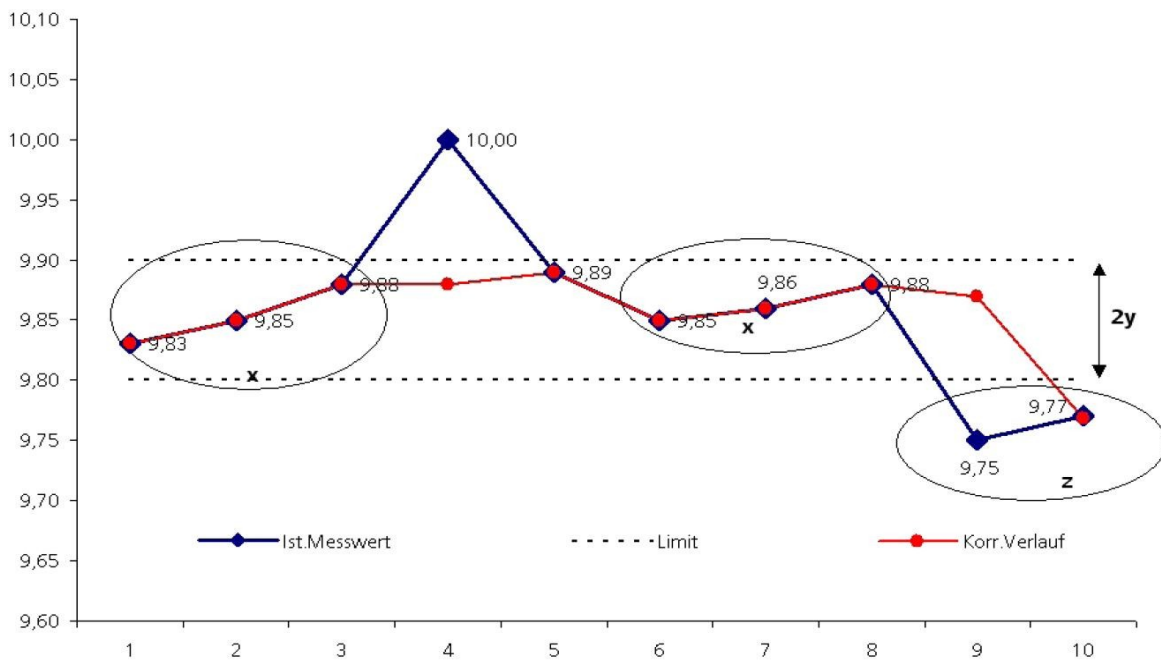

**Important:**

The use of RM parameter settings should be restricted to suitable applications only. Improper use of this parameter may create safety hazards!



**4.3.19 TD.....display/set trigger delay [0..9999ms] trigger level [0/1]**

Standard setting: 0 0

TD is solely intended for behavioral configuration of the remote trigger input (DF mode) (refer to section 4.3.5 for DF mode).

TD consists of two parameters which are separated by space (20h), one parameter containing the actual delay, i.e. the amount of delay time, and the other parameter the trigger level.

X corresponds to the delay in time from the arrival of a trigger signal to the start of a measurement. Delay settings may range from 0 to 9999 ms.

Y 0 for HIGH → LOW transition  
 1 for LOW → HIGH transition



- b) ASDM  
TM1 0  
Trigger signal=H → no change in state  
Trigger signal=L → DM active, i.e. one measurement is triggered

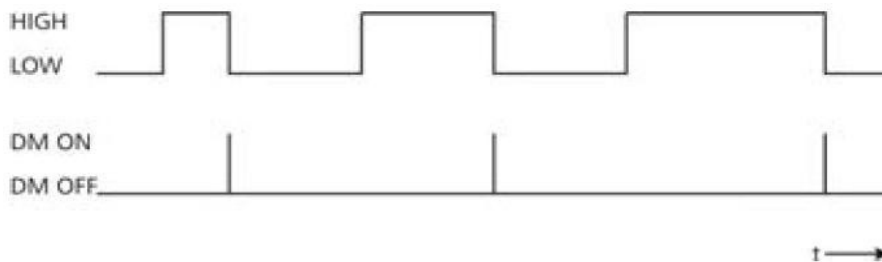

#### 4.3.21 BRx.....display/set baud rate [2400..38400]

Standard setting: 9600

Available baud rate BR settings are: 2400, 4800, 9600, 19200, 38400. Faulty entries will be rounded to the nearest baud rate. A fixed data format of eight data bits, with no parity and one stop bit is used.

**Note:**

After a change in baud rate setting, the communicating counterpart must also be set to the new baud rate.

#### 4.3.22 ASd....display/set autostart command [DT/DS/DW/DX/DF/DM/TP/LO/ID]

Standard setting: ID

AS (autostart) defines which function will be carried out when power becomes available to the LLD. Possible entries are those delivering a measured value on the output side, an ID command or the command for turning the laser on (LO). For example, if ASDT has been parameterized, the LLD will begin with distance tracking on turning on power.

#### 4.3.23 OFx.x.....display/set distance offset

Standard setting: 0

With the help of OF (offset) the user may define a zero-point for his/her application. For details on the position of the module's zero-point, refer to section 3.6 Mechanical Mounting Conditions. OF must be selected so it is properly matched to the currently valid scale factor setting(SF). OF may also take on negative values

## 4.3.24 SO.....set current distance to offset (offset = - distance)

SO performs a distance measurement and saves the measured reading as an offset value with inverted mathematical sign (OF).

## 4.3.25 LO.....laser on

LO turns the laser on. This function can be used for orientation or functional testing of the LLD.

## 4.3.26 LF.....laser off

LF turns the laser off.

## 4.3.27 PA.....display settings

PA lists all parameters in a table.

```

average value[SA].....1
display format[SD].....d
measure time[ST].....0
scale factor[SF].....1
error mode[SE].....1
ALARM center[AC].....20
ALARM hysteresis[AH].....0.1
ALARM width[AW].....10
distance of Iout=4mA [RB].....15
distance of Iout=20mA [RE].....25
remove measurement [RM].....0 0 0
trigger delay, trigger level[TD]..0 0
trigger mode, trigger level[TM]..0 1
baud rate[BR].....9600
autostart command[AS].....ID
distance offset[OF].....0
    
```

## 4.3.28 PR.....reset settings

PR resets all parameters (except for baud rate) to their standard settings.

```

average value[SA].....1
display format[SD].....d
measure time[ST].....0
scale factor[SF].....1
error mode[SE].....1
ALARM center[AC].....1000
ALARM hysteresis[AH].....0.1
ALARM width[AW].....100000
distance of Iout=4mA [RB].....1000
distance of Iout=20mA [RE].....2000
remove measurement [RM].....0 0 0
trigger delay, trigger level[TD]..0 0
trigger mode, trigger level[TM]..0 1
baud rate[BR].....9600
autostart command[AS].....ID
distance offset[OF].....0
    
```

## 5 Operating Modes

Make sure that all cable ends are protected against short circuit effects before you turn power supply on! Connect cable terminals as required for the particular operating mode. To prevent short circuits, you should seal unused cable ends! For starting up, a PC with RS232 or RS422 data interface and a terminal program such as the hyperterminal are required. As part of preparative actions, the LLD must be properly installed in the designated working site, oriented onto the target and kept in a stable position. The target to be measured should preferentially have a homogeneous, white surface.

**Caution: Do not use any retroreflectors!**



The LLD provides a visible laser beam for greater convenience in alignment. This laser beam can easily be turned on at the PC. Its visibility is conditional on the amount of ambient light present and on the type of surface of the target to be measured.

### 5.1 RS232

Initially, RS232 communication interfaces purely functioned as PC communication ports. They have become the established standard tool for serial data transmission over short cable lengths. With greater transmission lengths, the interface is highly susceptible to interferences, notably, in the vicinity of strong electromagnetic noise emitters. Therefore, it should only be used for LLD configuration.

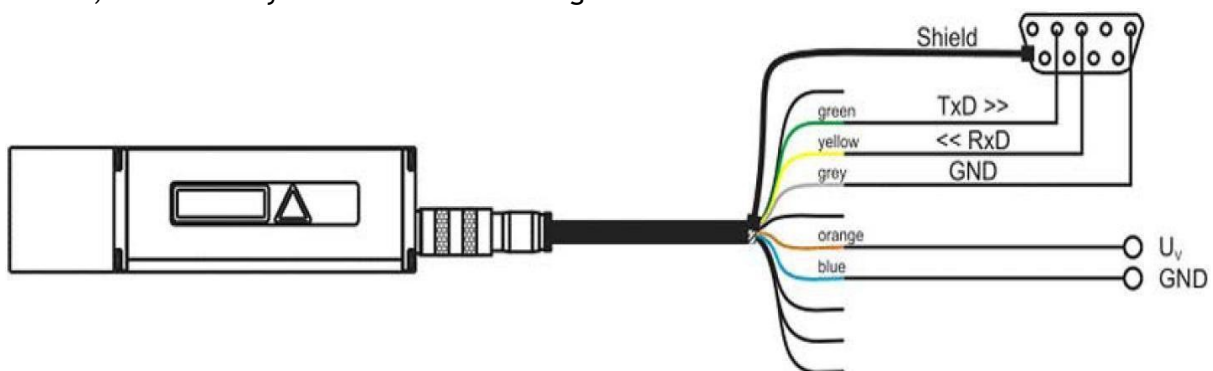

Figure 14: Diagram of RS232 wiring at 9-position D-Sub cable jack

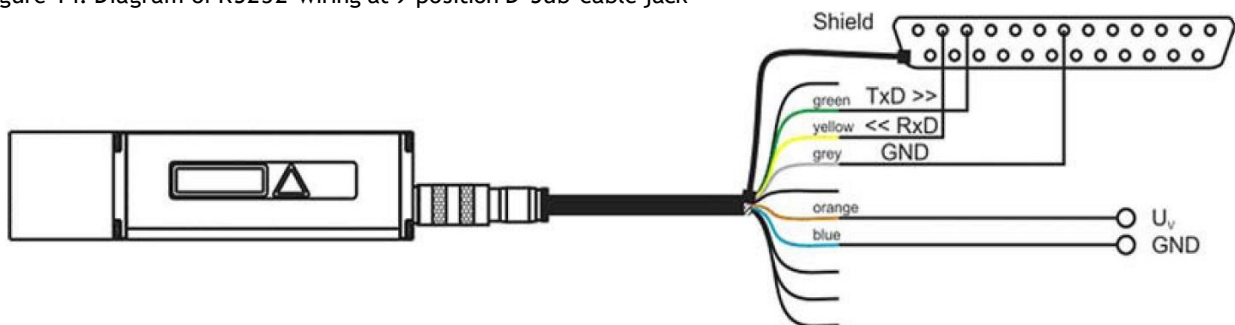

Figure 15: Diagram of RS232 wiring at 25-pole D-Sub cable jack

## 5.2 RS422

For configuration purposes and permanent data transmissions over a greater length, the RS422 can be used. This type of interface is insusceptible to interference and noise influences and qualifies for industrial use. Where twisted cable pairs are involved, transmissions lengths up to 1200 m can be handled.

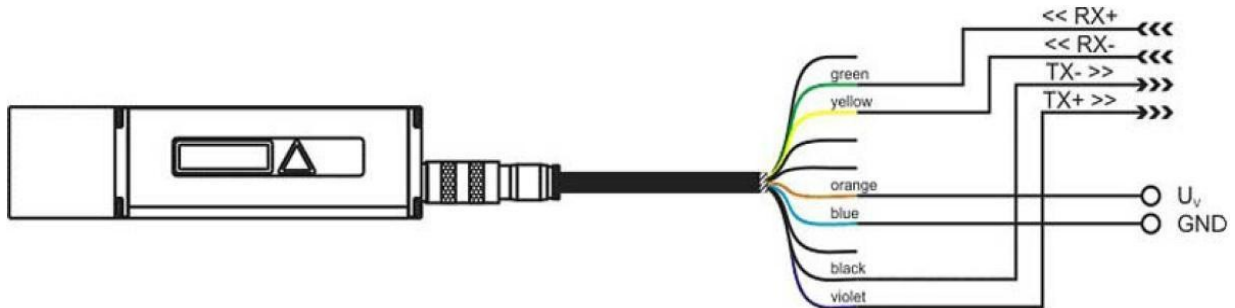

Figure 16: RS422 wiring diagram

Since a standard PC typically includes no RS422 communication port, you require an RS422 interface card or an RS422- to-RS232 converter for communication.

## 5.3 Digital Switching Output

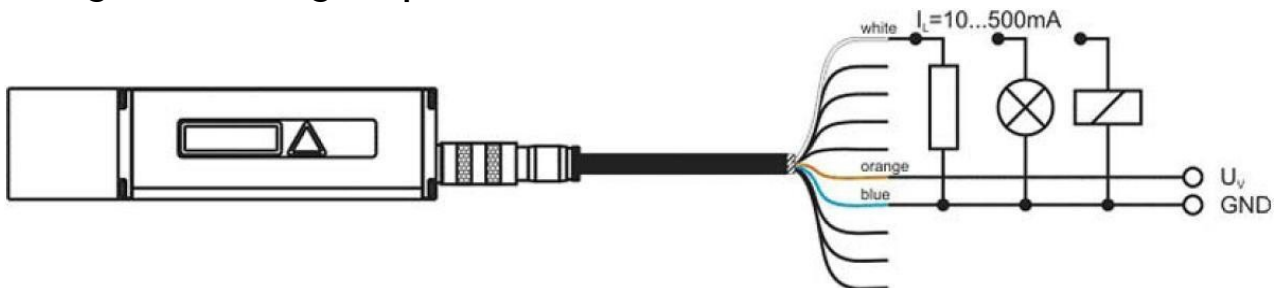

Figure 17: Wiring diagram of digital switching output

For example, using the digital switching output, an object which was selected for measurement can be monitored for excession of a threshold value. To do this, parameter settings for a measurement window are required. Settings for this window can be made via the three parameters: Alarm Center (AC), Alarm Hysteresis (AH) and Alarm Width (refer to sections 4.3.13 to 4.3.15). The range which will be subject to monitoring begins at AC and ends at AC+AW. Switching transitions can be set via parameter AH.

The logic state of the switching output follows from the mathematical sign of AH.

In the case of a *positive AH*, the output switches

- with increasing distance:

- from LOW to HIGH if the distance is found to be greater than  $(AC \pm AH/2)$ .
- from HIGH to LOW if the distance is found to be greater than  $(AC+AW+AH/2)$

- with decreasing distance:

- from LOW to HIGH if the distance is found to be smaller than  $(AC + AW - AH/2)$ .
- from LOW to HIGH the distance is found to be smaller than  $(AC - AH/2)$ .

In the case of a *negative AH*, the output switching pattern will be inverse.

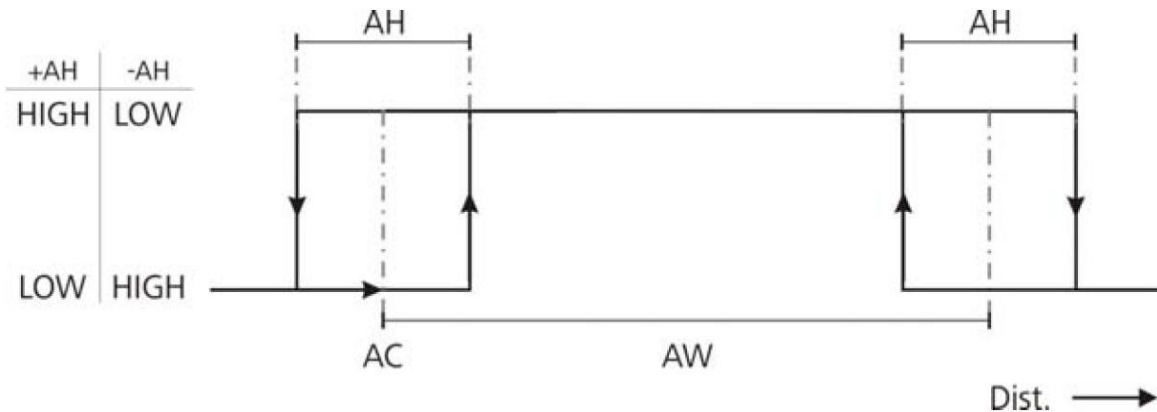

Figure 18: Digital switching output behavior with positive and negative hysteresis

### Example:

A moving object is assumed to be monitored within a window of 10 m to 11 m with a hysteresis of 0.2 m.

AC10  
AH0,2  
AW1

Distance (m) increases →

	9,8	9,9	10,0	10,1	10,2	...	11,0	11,1	11,2	11,3
+AH	L	L	L	H	H	H	H	L	L	H
-AH	H	H	H	L	L	L	L	H	H	H

Distance (m) decreases →

	11,3	11,2	11,1	11,0	10,9	10,8	...	10,0	9,9	9,8
+AH	L	L	L	L	H	H	H	H	H	L
-AH	H	H	H	H	L	L	L	L	L	H

L = LOW, H = HIGH

How the switching output is to behave on occurrence of an error message (E15, E16, E17, E18) can be defined by making suitable settings under "SE" (see 4.3.12).

## 5.4 Analog Output



Figure 19: Wiring diagram of analog output

The purpose of the analog output is to allow transmission of analog measured values via a 4 ... 20 mA interface.

The amount of current which is injected into the line of transmission is proportional to the distance measured. A given range of distances can be selected for transmission via the two parameters Range Beginning (RB) and Range End (RE) (refer to sections 4.3.16 and 4.3.17).

RE may be greater or smaller than RB.

The amount of injected current can be calculated as follows:

$$RE > RB: \quad I_{OUT} [mA] = 4 \text{ mA} + 16 \cdot \left( \frac{\text{Distanz} - RB}{RE - RB} \right) \cdot \text{mA}$$

$$RE < RB: \quad I_{OUT} [mA] = 20 \text{ mA} - 16 \cdot \left( \frac{\text{Distanz} - RE}{RB - RE} \right) \cdot \text{mA}$$

	Dist. < (RB..RE)	Dist. > (RB..RE)
RE > RB	4 mA	20 mA
RE < RB	20 mA	4 mA

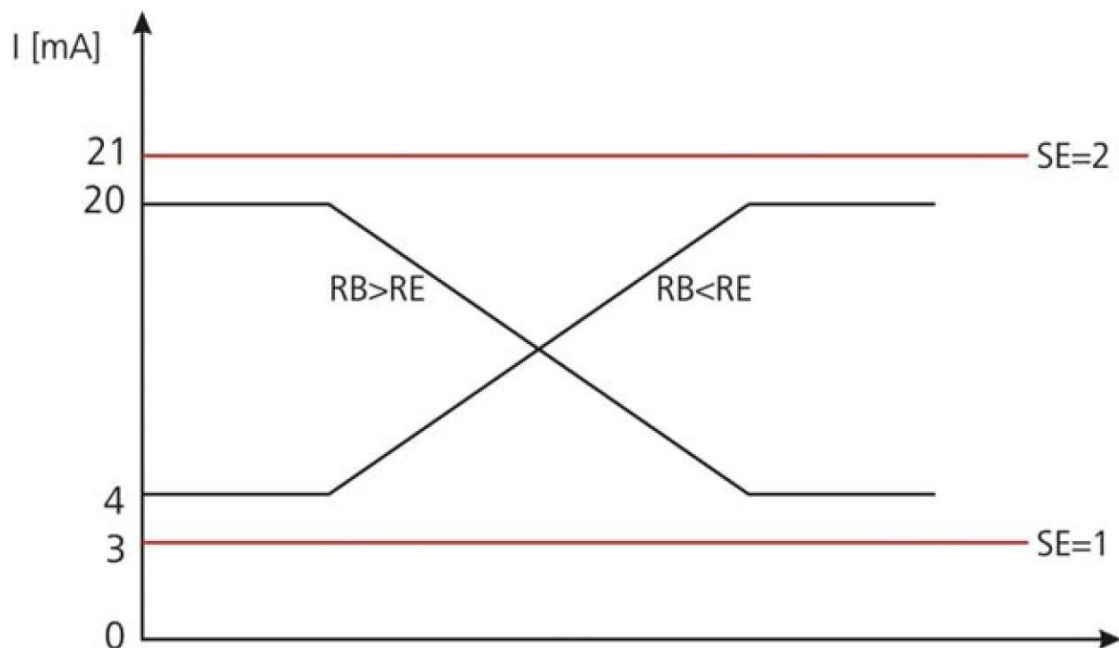

Figure 20: Output current diagram for RE > RB and RE < RB

On occurrence of an error message (E15, E16, E17, E18), the output current can be matched to 3 mA or 21 mA with the help of parameter SE (refer to section 4.3.12).

## 5.5 Trigger Input



Figure 21: Wiring diagram of trigger input

The trigger input is intended for triggering a distance measurement with an external signal that is applied as a voltage pulse between 3 V and 24 V. It is for the user to specify a desired delay time and a pulse flank to be selected for synchronization (see 4.2.16). Having done this, he/she must switch the LLD to trigger mode (DF).

## 6 Error Messages

Code	Description	Action for removal
E15	Excessively poor reflexes; Distance LLD (Front edge) ... target < 0,1m	Use target board, observe minimum requirement on measuring distance (> 0.1 m)
E16	Excessively strong reflexes	Use target board
E17	Too much steady light (e.g. sun)	Reduce ambient light at target, Reflecting objects remove or cover
E18	Only in DX mode: too much difference between measured and pre-calculated value	Check path from distance meter to target being measured for obstacles
E19	Only in DX mode (50 Hz): target motion speed > 10 m/s	Reduce motion speed of target or distance meter
E23	Temperature below -10 °C	Provide ambient temperature > -10°C
E24	Temperature above + 60 °C	Provide ambient temperature < +60°C
E31	Faulty EEPROM checksum, hardware error	Service required if fault occurs repeatedly - reship LLD for repair
E51	Failure to set avalanche voltage of diode laser 1. straylight or 2. hardware error	1. Check ambient light radiation; Limit ambient light 2. Service required - reship LLD for repair



E52	Laser current too high /laser defective	- reship LLD for repair, contact technical support
E53	One or more parameters in the EEPROM not set (Consequence: Division by 0)	1. Parameter SF examine ( SF must be unequal 0 ) 2. Contact technical support - reship LLD for repair
E54	Hardware error (PLL)	Contact technical support -reship LLD for repair
E55	Hardware error	Contact technical support -reship LLD for repair
E61	Used parameter is inadmissible, invalid command sent	Check control software commands
E62	1. Hardware error 2. wrong value in interface communication (Parity error SIO)	Check external software parity setting
E63	SIO overflow	Check time of emitted signals in application software, integrate delay on transmission if necessary
E64	Framing-Error SIO	Data format of the serial interface examine (8N1)

## 7 Service and Maintenance

**Please note:**

- A blower brush can be used to remove dust from optical surfaces (transmitter and receiver optics). You should refrain from the use of cleaners that contain organic solvents, when wiping optical surfaces down. You are also advised to contact the Manufacturer in the case of stubborn contamination or soiling.
- Do not use solvents of any kind to perform cleaning of the LLD.
- You are prohibited from opening the LLD.
- You are prohibited from loosening any screw at the LLD.



For necessary repair work, you should carefully pack the LLD and reship it to the appropriate dealer (or to us at this address) stating the conditions in which it has operated (applications, connections and environmental conditions):

WayCon Positionsmesstechnik GmbH  
Mehlbeerenstr. 4  
82024 Taufkirchen  
Germany

You may also contact us via phone or by fax before dispatching the LLD. We can be reached at:

Tel.: +49 89 67 97 13-0  
Fax: +49 89 67 97 13-250  
E-Mail: [info@waycon.de](mailto:info@waycon.de)  
Internet: [www.waycon.de](http://www.waycon.de)