



Manual

Digital Display WAY-AX

Product Features:

- Operating modes for visualization of input 1, input 2 or combinations of inputs (1+2, 1-2, 1x2, 1:2)
- Two universal 16 bit analog inputs for $-10 \dots +10 \text{ V} / 0 \dots 10 \text{ V} / 0 \dots 20 \text{ mA} / 4 \dots 20 \text{ mA}$
- High accuracy reference output 10 V for potentiometers $> 1 \text{ k}\Omega$
- Bright and high-contrast display with event-dependent colour variations
- Emulation of a 7-segment display inclusively icons and units
- Intuitive and easy parameterization by plain text and touchscreen
- 24 V auxiliary output for encoder supply
- Totalization for each input
- Linearization with 24 control points for each input
- Numerous features, e. g. tara, averaging filter, sampling time for each input
- 96 x 48 mm norm panel housing and IP65 protection

Available Options:

- WAY-AX-S:** Basic unit with 2 analog inputs (16 Bit), 3 control inputs
- Option **AC:** Power supply 115...230 VAC
 - Option **AO:** 16-bit analog output, 4 control outputs, serial RS232 interface
 - Option **AR:** 16-bit analog output, 4 control outputs, serial RS485 interface
 - Option **CO:** 4 control outputs, serial RS232 interface
 - Option **CR:** 4 control outputs, serial RS485 interface
 - Option **RL:** 2 relay outputs

Options can be combined

Legal notices:

All contents included in this manual are protected by the terms of use and copyrights of WayCon Positionsmesstechnik GmbH. Any reproduction, modification, usage or publication in other electronic and printed media as well as in the internet requires prior written authorization by WayCon Positionsmesstechnik GmbH.

Table of Contents

1. Safety Instructions and Responsibility	5
1.1. General Safety Instructions	5
1.2. Use according to the intended purpose.....	5
1.3. Installation.....	6
1.4. EMC Guidelines.....	6
1.5. Cleaning, Maintenance and Service Notes	6
2. Introduction	7
2.1. Operation mode.....	7
2.2. Function diagram	8
3. Electrical Connections	9
3.1. DC Power Supply	9
3.2. Auxiliary Voltage Output.....	9
3.3. Analog Input.....	10
3.4. Reference-output.....	10
3.5. Control Inputs	11
3.6. Analog Output (Option AO/AR).....	11
3.7. Serial interface (Option AO/AR/CO/CR)	12
3.8. Control-Output (Option AO/AR/CO/CR).....	12
3.9. AC Power supply (Option AC).....	13
3.10. Relay-Output (Option RL).....	13
4. Operation and touch screen	14
4.1. Screen structure for parametrization.....	14
4.2. Screen structure in operation.....	15
4.3. Error messages.....	18
5. Parameter / Overview-Menu Structure.....	21
5.1. General Menu	23
5.2. IN 1 Properties.....	24
5.3. IN 1 Linearization	26
5.4. IN 1 Totalization.....	27
5.5. IN 2 Properties.....	28
5.6. IN 2 Linearization	29
5.7. IN 2 Totalization.....	29
5.8. Linkage Properties.....	30
5.9. Preselection Values	31
5.10. Preselection 1 Menu	31
5.11. Preselection 2 Menu	34
5.12. Preselection 3 Menu	35
5.13. Preselection 4 Menu	36
5.14. Serial Menu.....	37
5.15. Analog Out Menu.....	39
5.16. Command Menu	41
5.17. Display Menu.....	42
6. Appendix.....	48
6.1. Data readout via serial interface.....	48
6.2. Modbus RTU Interface.....	49
6.2.1. Parameter setting.....	49
6.2.2. Modbus Communication	50
6.2.3. Diagnostics	51

6.3. Display of scale units	52
6.4. Parameter / serial codes	53
6.5. Linearization	60
6.6. Dimensions	62
6.7. Technical specifications.....	63

1. Safety Instructions and Responsibility

1.1. General Safety Instructions

This operation manual is a significant component of the unit and includes important rules and hints about the installation, function and usage. Non-observance can result in damage and/or impairment of the functions to the unit or the machine or even in injury to persons using the equipment!

Please read the following instructions carefully before operating the device and observe all safety and warning instructions! Keep the manual for later use.

A pertinent qualification of the respective staff is a fundamental requirement in order to use this manual. The unit must be installed, connected and put into operation by a qualified electrician.

Liability exclusion: The manufacturer is not liable for personal injury and/or damage to property and for consequential damage, due to incorrect handling, installation and operation. Further claims, due to errors in the operation manual as well as misinterpretations are excluded from liability.

In addition, the manufacturer reserves the right to modify the hardware, software or operation manual at any time and without prior notice. Therefore, there might be minor differences between the unit and the descriptions in operation manual.

The raiser respectively positioner is exclusively responsible for the safety of the system and equipment where the unit will be integrated.

During installation or maintenance all general and also all country- and application-specific safety rules and standards must be observed.

If the device is used in processes, where a failure or faulty operation could damage the system or injure persons, appropriate precautions to avoid such consequences must be taken.

1.2. Use according to the intended purpose

The unit is intended exclusively for use in industrial machines, constructions and systems. Non-conforming usage does not correspond to the provisions and lies within the sole responsibility of the user. The manufacturer is not liable for damages which have arisen through unsuitable and improper use.

Please note that device may only be installed in proper form and used in a technically perfect condition (in accordance to the Technical Specifications). The device is not suitable for operation in explosion-proof areas or areas which are excluded by the EN 61010-1 standard.

1.3. Installation

The device is only allowed to be installed and operated within the permissible temperature range. Please ensure an adequate ventilation and avoid all direct contact between the device and hot or aggressive gases and liquids.

Before installation or maintenance, the unit must be disconnected from all voltage-sources. Further it must be ensured that no danger can arise by touching the disconnected voltage-sources.

Devices which are supplied by AC-voltages must be connected exclusively by switches, respectively circuit-breakers with the low voltage network. The switch or circuit-breaker must be placed as near as possible to the device and further indicated as separator.

Incoming as well as outgoing wires and wires for extra low voltages (ELV) must be separated from dangerous electrical cables (SELV circuits) by using a double resp. increased isolation.

All selected wires and isolations must be conform to the provided voltage- and temperature-ranges. Further all country- and application-specific standards, which are relevant for structure, form and quality of the wires, must be ensured. Indications about the permissible wire cross-sections for wiring are described in the Technical Specifications.

Before first start-up it must be ensured that all connections and wires are firmly seated and secured in the screw terminals. All (inclusively unused) terminals must be fastened by turning the relevant screws clockwise up to the stop.

Overvoltages at the connections must be limited to values in accordance to the overvoltage category II.

1.4. EMC Guidelines

All motrona devices are designed to provide high protection against electromagnetic interference. Nevertheless you must minimize the influence of electromagnetic noise to the device and all connected cables.

Therefore the following measures are mandatory for a successful installation and operation:

- **Use shielded cables for all signal and control input and output lines.**
- **Cables for digital controls (digital I/O, relay outputs) must not exceed a length of 30 m and are allowed for in building operation only**
- Use shield connection clamps to connect the cable shields properly to earth
- The wiring of the common ground lines must be star-shaped and common ground must be connected to earth at only one single point
- The device should be mounted in a metal enclosure with sufficient distance to sources of electromagnetic noise.
- Run signal and control cables apart from power lines and other cables emitting electromagnetic noise.

1.5. Cleaning, Maintenance and Service Notes

To clean the front of the unit please use only a slightly damp (not wet!), soft cloth. For the rear no cleaning is necessary. For an unscheduled, individual cleaning of the rear the maintenance staff or assembler is self-responsible.

During normal operation no maintenance is necessary. In case of unexpected problems, failures or malfunctions the device must be shipped for back to the manufacturer for checking, adjustment and reparation (if necessary).

Unauthorized opening and repairing can have negative effects or failures to the protection-measures of the unit.

2. Introduction

This series of display unit is suitable for analog signals (-10 ... 10V or 0/4 ... 20 mA). It is very versatile in use, due to the intuitive handling and the extensive range of functions and options.

2.1. Operation mode

All functions are can be configured in the parameter menu.

The device can be set to one of the following operation modes:

- SINGLE:
single-channel operation of input 1
- DUAL:
two-channel operation of input 1 and 2
- IN 1 + IN 2:
two-channel operation of input 1 and 2 in combination with sum
- IN 1 - IN 2:
two-channel operation of input 1 and 2 in combination with difference.
- IN 1 x IN 2:
two-channel operation of input 1 and 2 in combination with multiplication
- IN 1 / IN 2:
two-channel operation of input 1 and 2 in combination with division.

2.2. Function diagram

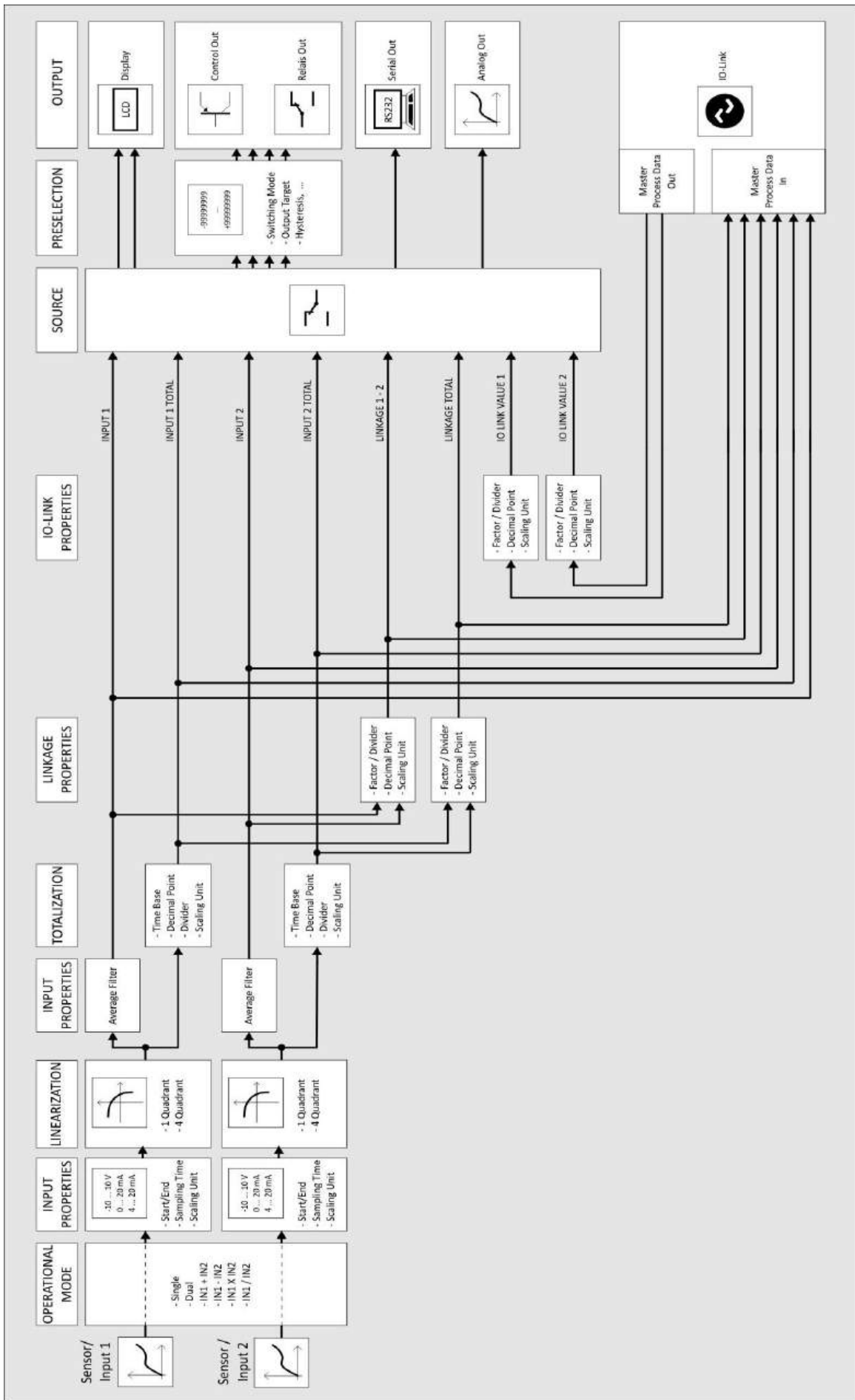

3. Electrical Connections

The terminal screws should be tightened with a slotted screwdriver (blade width 2mm).

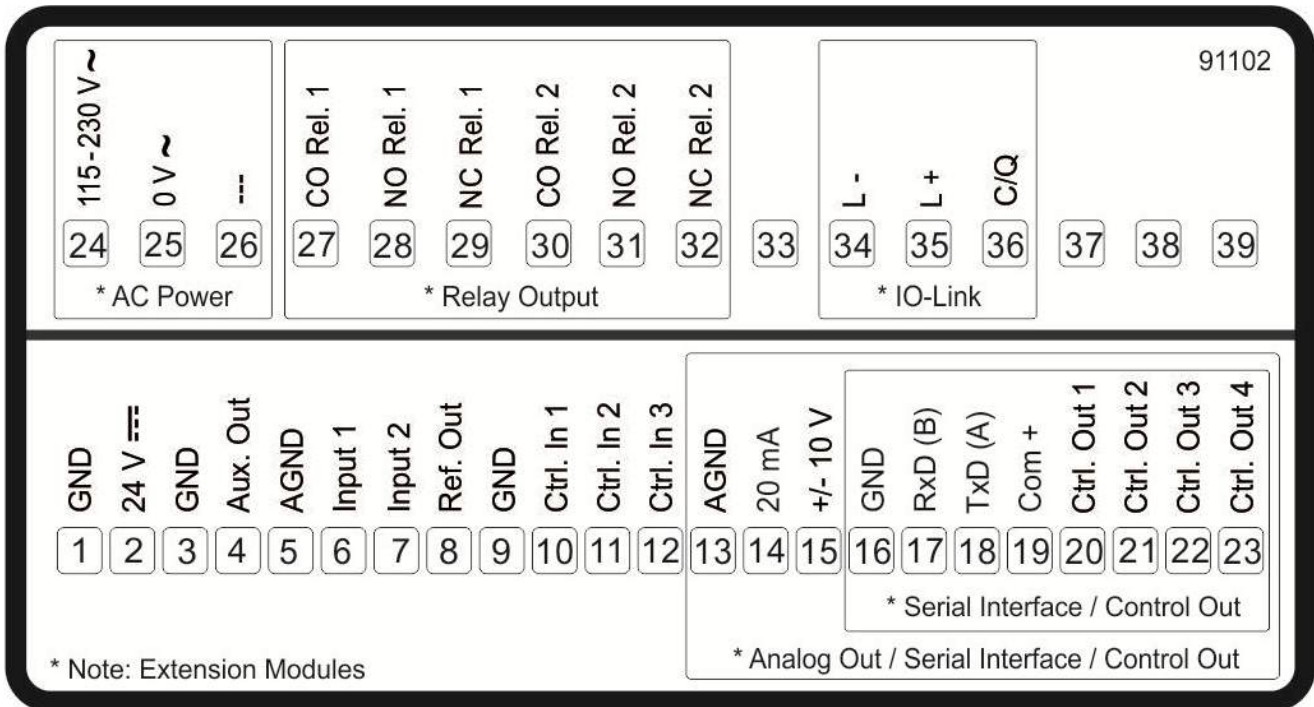

3.1. DC Power Supply

The unit accepts DC supply from 18 to 30 V at the terminals 1 and 2. The power consumption depends on the level of the supply voltage with approx. 100 mA and the additional current required at the auxiliary voltage output.

All GND terminals are internally interconnected.

3.2. Auxiliary Voltage Output

Terminal 3 and 4 provide an auxiliary output for supply of sensors and encoders. The output voltage depends on the power supply.

DC version	AC version
The encoder voltage is approx. 1 V lower than the power supply voltage at terminal 1 and 2 and should be loaded with max. 250 mA.	The encoder voltage is 24 VDC ($\pm 15\%$) and should be loaded with max. 150 mA up to 45 °C. At higher temperature the maximum output current is reduced to 80 mA.

3.3. Analog Input

The reference potential (AGND) for the analog inputs is connected at terminal 5.

The unit provides two 16 bit analog inputs at terminal 6 and 7. The characteristics of the analog inputs (voltage input or current input) can be set in the Menu IN 1/IN 2 PROPERTIES.



Important:
Before connecting the sensor, the configuration (voltage or current input) must be set!

Wiring of the analog inputs:

Voltage input

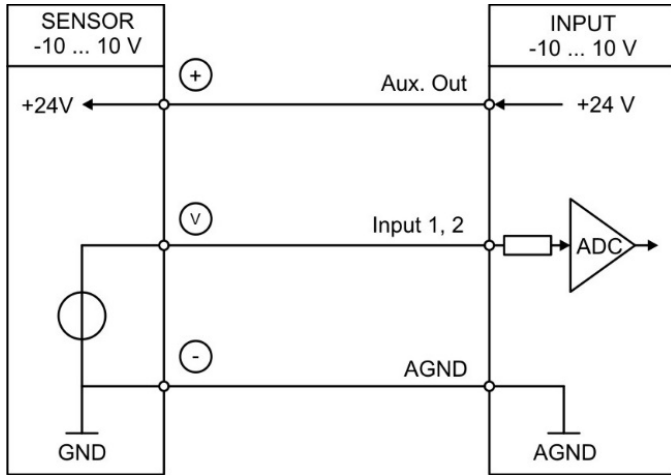

Current input

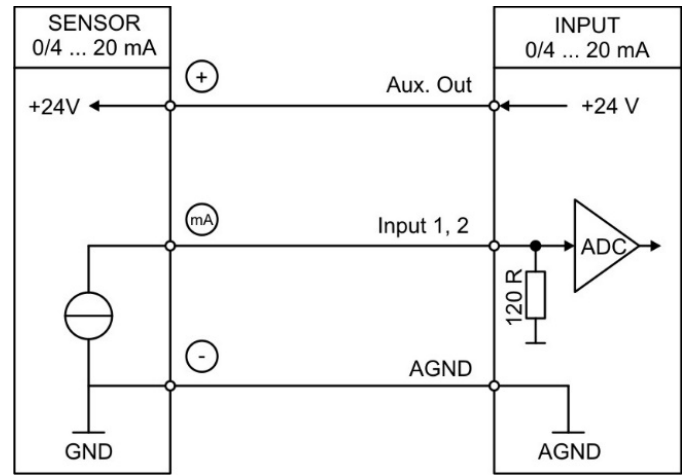

3.4. Reference-output

The unit provides a 10 V reference-output at terminal 8. This output should be loaded with 10 mA maximum. This reference-output can be used for connecting a potentiometer.

Reference output with potentiometer:

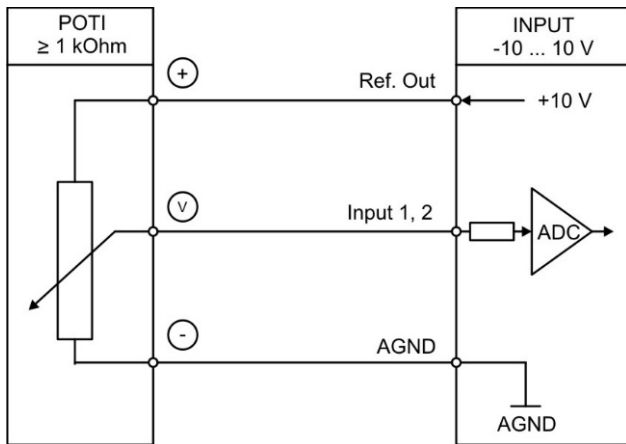

3.5. Control Inputs

The three control inputs at terminal 10, 11 and 12 have HTL PNP characteristics.

In the COMMAND MENU the programmable functions for the control inputs can be assigned. Available functions are: reset the display value, display switching, locking the touch screen or release the lock function of the control or relay outputs.

Wiring of the control inputs:

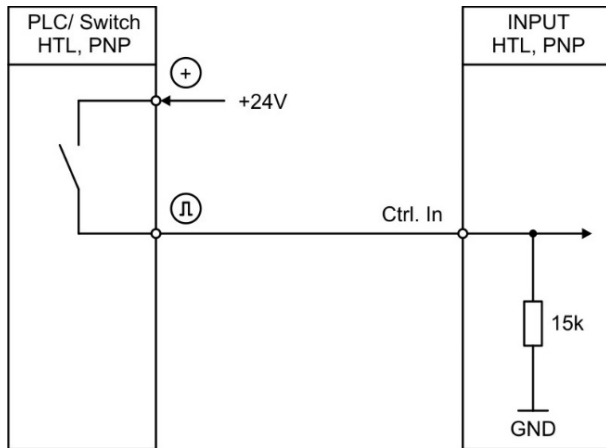

Unconnected control inputs are always "LOW".

All inputs are designed to receive impulses from an electronic impulse source.

Notice for mechanical switching contacts:

When exceptionally mechanical contacts are used, please connect an external capacitor between GND (-) and the corresponding input (+). A capacity of 10 μF will reduce the input frequency to 20 Hz and miscounting due to contact bouncing will be eliminated.

3.6. Analog Output (Option AO/AR)

A 16-bit analog output is available at terminal 13 and 14 / 15.

This output can be configured and scaled in the ANALOG MENU.

The following configuration is possible:

- Voltage output: -10 ... +10 V
- Current output: 0 ... 20 mA
- Current output: 4 ... 20 mA

The analog output is proportional to the reference source and is referenced to potential AGND. AGND and GND are internally interconnected.



Important:

A parallel operation with voltage and current output at the analog output is not allowed.

3.7. Serial interface (Option AO/AR/CO/CR)

A serial interface (RS232 or RS485) is available at terminal 16, 17 und 18. This interface can be configured in the SERIAL MENU.

The serial interface RS232 or RS485 can be used:

- for easy setup and commissioning of the units
- to modify settings and parameters during operation
- to read out internal states and actual measuring values by PC or PLC

The following drawing shows the connection to a PC by using a standard Sub-D-9 connector:

Connection of the RS232 interface:

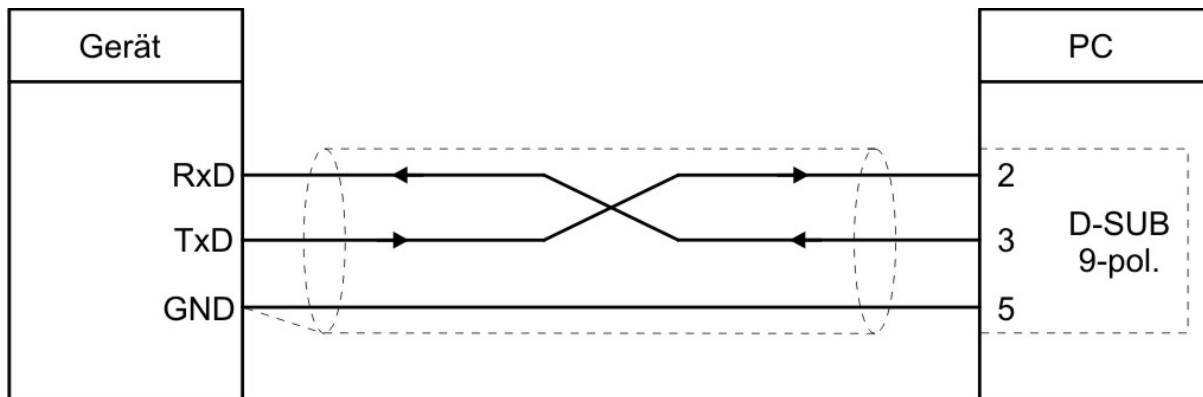

Connection of the RS485 interface:

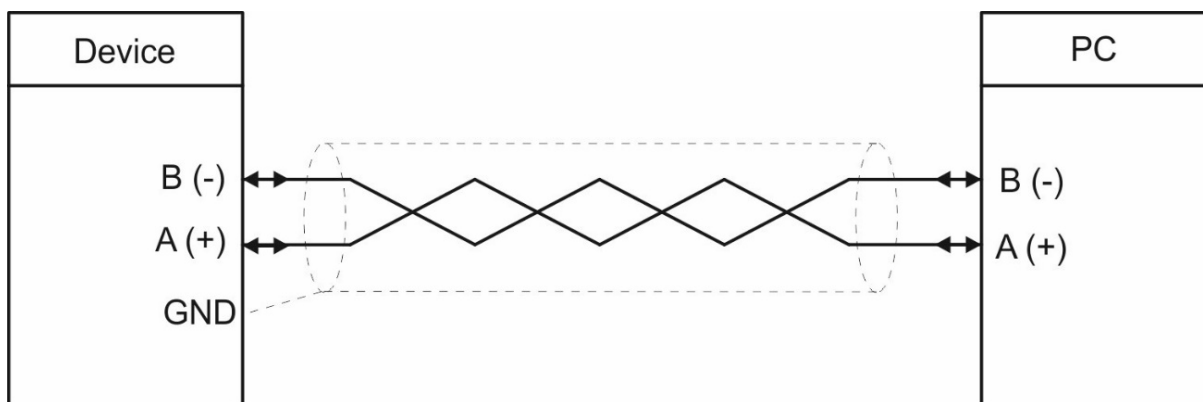

3.8. Control-Output (Option AO/AR/CO/CR)

Four control outputs are available at terminal 20, 21, 22 and 23.

Switching conditions can be set in the PRESELECTION MENU. The output Ctrl. Out1 – 4 are fast PNP outputs with a switching capability of 5 – 30 Volt / 200 mA per channel. The switching states is displayed (display with unit and status bar) as C1 ... C4.

The switching voltage of the outputs must be applied to input terminal 19 (COM+).

In case of switching inductive loads, it is advisable to use external filtering of the coils. The switching states is displayed (display with unit and status bar) as C1 and C4.

Wiring of the control-outputs:

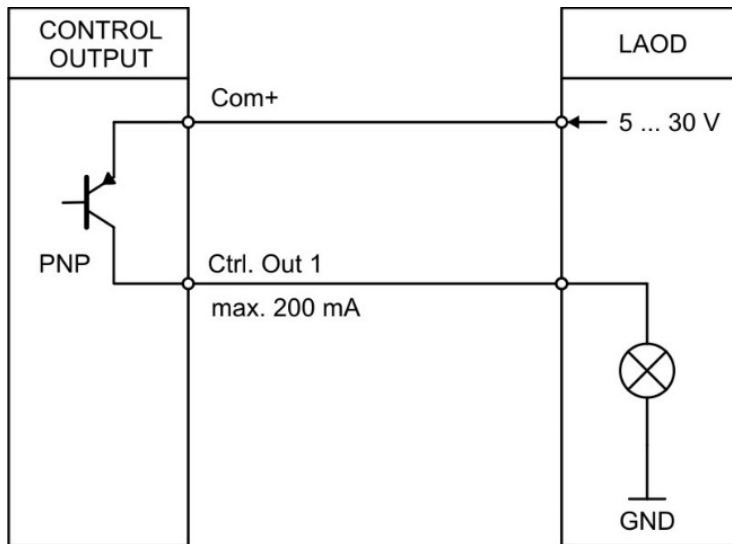

3.9. AC Power supply (Option AC)

The unit accepts AC supply from 115 to 230 V at the terminals 24 and 25. The power consumption depends on the level of the supply voltage with approx. 3VA and the additional current required at the auxiliary voltage output.

Devices with option AC can also be supplied with a DC voltage between 18 and 30 VDC at terminals 1 and 2.

3.10. Relay-Output (Option RL)

Two relay outputs with potential-free changeover contacts are available at terminal 27, 28, 29 and 30, 31, 32. Switching conditions can be set in the PRESELECTION MENU. The switching states are displayed (display with unit and status bar) as K1 and K2.

AC-switching capacity max 250 VAC/max. 3 A / max 750 VA

DC-switching capacity max 150 VDC /max. 2 A / max 50 W

Wiring of the relay outputs:

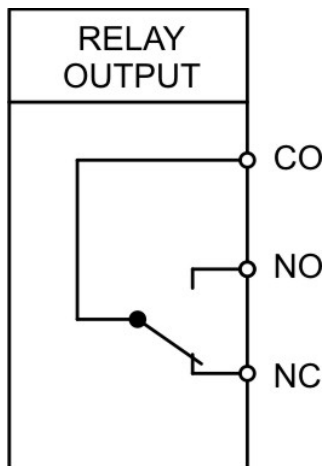

4. Operation and touch screen

4.1. Screen structure for parametrization

The parameter menus and the parameters are described in chapter 5.



Start setup procedure:

To edit the parameters, press the touchscreen for 3 seconds.



Menu selection:

Select the parameter menu via arrow buttons and confirm with "OK".

The menu selection can be terminated with „C“.



Parameter selection:

Select the parameter via arrow buttons and confirm with „OK“.

The parameter selection can be terminated with „C“.



Parameter editing:

Edit the parameter via arrow button up and down, shift cursor via left and right and save with „OK“.

The parameter editing can be terminated with „C“.

Parameter changes becomes active only after closing the menu selection

4.2. Screen structure in operation

The following screens are available during operation. Depending on the device version and the selected operation mode, not all displays will be shown. The individual display windows can be activated or deactivated in the DISPLAY MENU.

The source (IN1, IN2, ...) for the single channel display, the two-channel display, the large display and bar graph display are defined in the DISPLAY MENU.



Single line display with unit and status bar

To switch to the next display, press the touch screen.

Control - or Relay status are only shown with Option AO, AR, CO, CR or RL.



Two-line display

To switch to the next display, press the top of the screen.

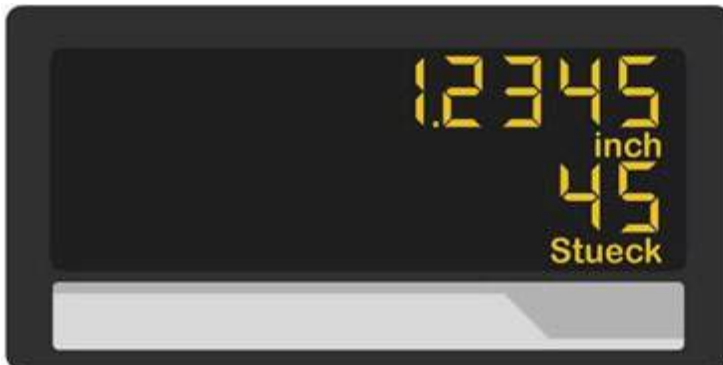

Two-line display with units

To switch to the next display, press the top of the screen.



Display for quick start for enter preselection values (PRESELECTION VALUES)

To switch to the next display, press the top of the screen.

This is only possible with Option AO, AR CO, CR or RL

Continuation "Screen structure in operation":



Display with tare function for input 1 and input 2

To switch to the next display, press the top of the screen.



Large Display (4 digits)

To switch to the next display, press the top of the screen.



Bar graph display (5 digits with unit)

Graph type: UNIPOLAR RAMP

To switch to the next display, touch the screen.



Bar graph display (5 digits with unit)

Graph type: BIPOLAR RAMP

To switch to the next display, touch the screen.



Bar graph display (5 digits with unit)

Graph type: UNIPOLAR BEAM

To switch to the next display, touch the screen.



Bar graph display (5 digits with unit)

Graph type: BIPOLAR BEAM

To switch to the next display, touch the screen.



Bar graph display (5 digits with unit)

Graph type: CURSOR

To switch to the next display, touch the screen.



Display with actual / minimum / maximum values of input 1 and input 2

To switch to the next display, type on the touch screen.



Note:

If all display windows in the display menu have been switched off, the display shows:

„NO WINDOW SELECT!“

4.3. Error messages



ERROR: MAXIMUM DISPLAY VALUE

The display value of the single line display is greater than +99 999 999



ERROR: MINIMUM DISPLAY VALUE

The display value of the single line display is less than -99 999 999



ERROR: MAX. TOP DISPLAY VALUE

Top display value of the two-line display is greater than +99 999 999



ERROR: MIN. TOP DISPLAY VALUE

Top display value of the two-line display is less than -99 999 999



ERROR: MAX. DOWN DISPLAY VALUE

Down display value of the two-line display is greater than +99 999 999

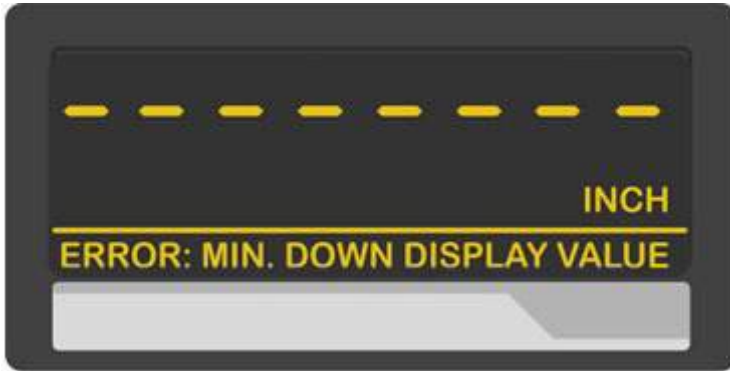

ERROR: MIN. DOWN DISPLAY VALUE

Down display value of the two-line display is less than -99 999 999



ERROR: MAX. LARGE DISPLAY VALUE

The display value of the large display is greater than + 9999



ERROR: MIN. LARGE DISPLAY VALUE

The display value of the large display is less than - 999

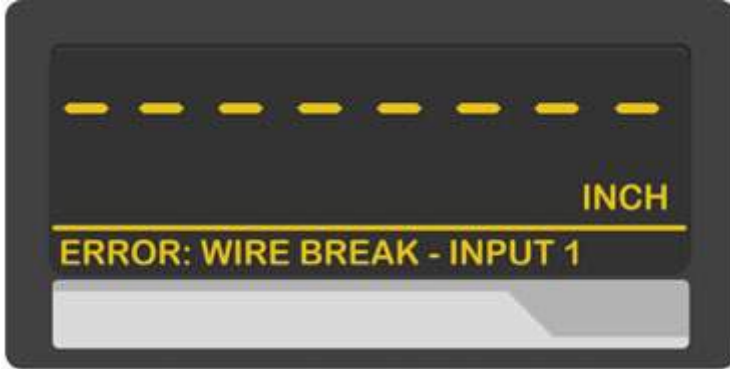

ERROR: WIRE BREAK – INPUT 1

Wire break detection of input 1 (4...20mA) is active.

→ current < 3mA

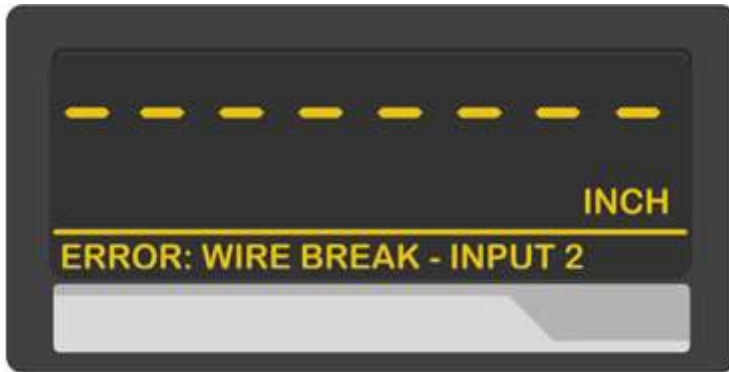

ERROR: WIRE BREAK – INPUT 2

Wire break detection of input 2 (4...20mA) is active.

→ current < 3mA

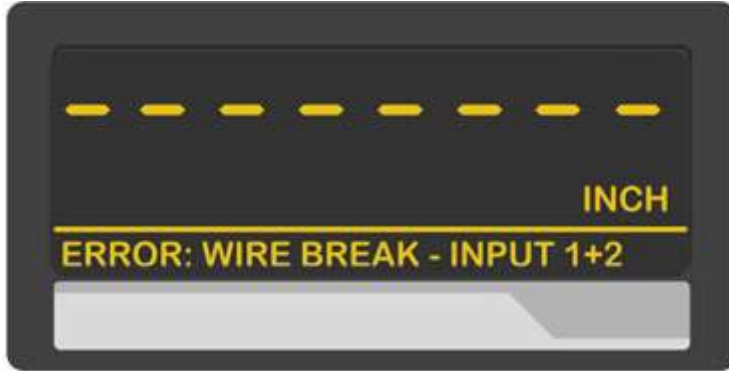

ERROR: WIRE BREAK – INPUT 1+2

Wire break detection of input 1 and 2 (4...20 mA) are active.



The error messages described are automatically reset as soon as the corresponding display value is within the representable range or the displayed error is no longer present.

5. Parameter / Overview-Menu Structure

The parameterization of the device is realized via the touch screen.

This section provides an overview of the menus and their parameters. The menu names are printed bold and the associated parameters are listed under the menu name. Depending on the device version and the selected operation mode, only the necessary menus / parameters are shown.

Menu / Parameter
GENERAL MENU
OPERATIONAL MODE PIN PRESELECTION PIN PARAMETER BACK UP MEMORY FACTORY SETTINGS
IN 1 PROPERTIES
CONFIGURATION START VALUE END VALUE DECIMAL POINT SCALE UNITS SAMPLING TIME AVERAGE FILTER OFFSET LINEARIZATION TOTALIZATION
IN 1 LINEARIZATION
P1(X) P1(Y) P2(X) P2(Y) P23(X) P23(Y) P24(X) P24(Y)
IN 1 TOTALIZATION
TIME BASE DIVIDER DECIMAL POINT SCALE UNITS

Menu / Parameter
IN 2 PROPERTIES
CONFIGURATION START VALUE END VALUE DECIMAL POINT SCALE UNITS SAMPLING TIME AVERAGE FILTER OFFSET LINEARIZATION TOTALIZATION
IN 2 LINEARIZATION
P1(X) P1(Y) P2(X) P2(Y) P23(X) P23(Y) P24(X) P24(Y)
IN 2 TOTALIZATION
TIME BASE DIVIDER DECIMAL POINT SCALE UNITS
LINKAGE PROPERTIES
FACTOR DIVIDER ADDITIVE VALUE DECIMAL POINT SCALE UNITS

Menu / Parameter
IO LINK PROPERTIES
IN1 FACTOR IN1 DIVIDER IN1 ADDITIVE VALUE IN1 DECIMAL POINT IN1 SCALE UNITS IN2 FACTOR IN2 DIVIDER IN2 ADDITIVE VALUE IN2 DECIMAL POINT IN2 SCALE UNITS
PRESELECTION VALUES
PRESELECTION 1 PRESELECTION 2 PRESELECTION 3 PRESELECTION 4
PRESELECTION 1 MENU
SOURCE 1 MODE 1 HYSTERESIS 1 PULSE TIME 1 OUTPUT TARGET 1 OUTPUT POLARITY 1 OUTPUT LOCK 1 START UP DELAY 1 EVENT COLOR 1
PRESELECTION 2 MENU
SOURCE 2 MODE 2 HYSTERESIS 2 PULSE TIME 2 OUTPUT TARGET 2 OUTPUT POLARITY 2 OUTPUT LOCK 2 START UP DELAY 2 EVENT COLOR 2
PRESELECTION 3 MENU
SOURCE 3 MODE 3 HYSTERESIS 3 PULSE TIME 3 OUTPUT TARGET 3 OUTPUT POLARITY 3 OUTPUT LOCK 3 START UP DELAY 3 EVENT COLOR 3

Menu / Parameter
PRESELECTION 4 MENU
SOURCE 4 MODE 4 HYSTERESIS 4 PULSE TIME 4 OUTPUT TARGET 4 OUTPUT POLARITY 4 OUTPUT LOCK 4 START UP DELAY 4 EVENT COLOR 4
SERIAL MENU
UNIT NUMBER SERIAL BAUD RATE SERIAL FORMAT SERIAL INIT SERIAL PROTOCOL SERIAL TIMER SERIAL VALUE MODBUS
ANALOG OUT MENU
ANALOG SOURCE ANALOG FORMAT ANALOG START ANALOG END ANALOG GAIN ANALOG OFFSET
COMMAND MENU
INPUT 1 ACTION INPUT 1 CONFIG INPUT 2 ACTION INPUT 2 CONFIG INPUT 3 ACTION INPUT 3 CONFIG
DISPLAY MENU
START DISPLAY SHOW SINGLE WINDOW SOURCE SINGLE SHOW DUAL WINDOW SOURCE DUAL TOP SOURCE DUAL DOWN SHOW LARGE WINDOW SOURCE LARGE LARGE DIVIDER SHOW GRAPH WINDOW SOURCE GRAPH GRAPH TYPE GRAPH LEFT END GRAPH RIGHT END SHOW PRESEL. WINDOW SHOW COMMAND WINDOW SHOW MIN/MAX WINDOW START DISPLAY SOURCE SINGLE SOURCE DUAL TOP SOURCE DUAL DOWN LARGE DISPLAY SOURCE LARGE COLOR BRIGHTNESS CONTRAST SCREEN SAVER UP-DATE-TIME FONT

5.1. General Menu

OPERATIONAL MODE

This parameter specifies the selected measuring function.

	0	SINGLE	Single channel mode, only input 1
	1	DUAL	Dual channel mode, input 1 and input 2 separated
	2	IN1 + IN 2	Dual channel mode, sum of input 1 and input 2
	3	IN1 – IN 2	Dual channel mode, difference of input 1 and input 2
	4	IN1 x IN 2	Dual channel mode, multiplication of input 1 and input 2
	5	IN1 / IN 2	Dual channel mode, input 1 divide by input 2

PIN PRESELECTION

This parameter defines the PIN-code to lock the quick start of the menu PRESELECTION VALUE for entering the preselection values. (master PIN 6079).

This Lock function is only useful in conjunction with active lock function in PIN PARAMETER

	0000	No lock
	...	
	9999	Access after entering PIN-Code 9999

PIN PARAMETER

This parameter defines the PIN-code for lock function of all parameters (master PIN 6079).

	0000	No lock
	...	
	9999	Parameterization of the unit after entering PIN-code 9999

BACK UP MEMORY

	0	NO	No back –up by power failure
	1	YES	Backup by power failure, actual value will be saved, only by totalization

FACTORY SETTINGS

	0	NO	No default values are loaded
	1	YES	Load default values of all parameters (grey marked default values)

5.2. IN 1 Properties

This menu defines the parameter for input 1.

CONFIGURATION		
This parameter defines the configuration of input 1.		
0	-10 ... 10 V	-10 ... 10 V
1	0 ... 20 MA	0 ... 20 mA
2	4 ... 20 MA	4 ... 20 mA

START VALUE		
This parameter defines the display value of an input signal of 0V, 0mA or 4mA. Signal values between START VALUE and END VALUE behave proportional.		
	-99999999	Smallest start value
	0	Default value
	99999999	Highest start value

END VALUE		
This parameter defines the display value of an input signal +10V or 20mA. Signal values between START VALUE and END VALUE behave proportional.		
	-99999999	Smallest end value
	10000	Default value
	99999999	Highest end value

DECIMAL POINT		
This value defines the position of the decimal point.		
0	NO	No decimal point
1	0000000.0	Decimal point at the specified position
2	000000.00	Decimal point at the specified position
3	00000.000	Default decimal point at the specified position
4	0000.0000	Decimal point at the specified position
5	000.00000	Decimal point at the specified position
6	00.000000	Decimal point at the specified position
7	0.0000000	Decimal point at the specified position

SCALE UNITS		
This parameter defines the required engineering unit. This parameter does not affect the calculation of the display value. The number of decimal places must be defined with the parameter DECIMAL POINT. A list of available units can be found in Chapter 6.2 Appendix: Display of scale units.		

Continuation "IN 1 Properties":

SAMPLING TIME (S)		
The configured value corresponds to the sampling interval. This time interval in seconds defines the time between the single samples of the analog signals. This parameter directly affects the response time of the unit.		
	0,001	Shortest sampling time
	0,01	Default value
	60,000	Longest sampling time

AVERAGE FILTER		
Selectable average filter function to avoid measuring fluctuations.		
	0	No average value will be created
	1	2 numbers of floating average cycles
	2	4 numbers of floating average cycles
	3	8 numbers of floating average cycles
	4	16 numbers of floating average cycles

OFFSET		
This parameter defines the zero offset / tara of the input. This parameter does not affect the TOTALIZATION function.		
	-99999999	Smallest offset
	0	Default value
	+99999999	Highest offset

LINEARIZATION			
This parameter defines the linearization function. The linearization points are defined in Menu IN 1 / IN 2 LINEARIZATION. See appendix.			
	0	OFF	No linearization
	1	1 QUADRANT	Linearization in the 1. quadrant
	2	4 QUADRANT	Linearization in all 4 quadrants

TOTALIZATION			
This parameter activates the totalization function. The settings will be done in Menu IN 1 / IN 2 TOTALIZATION. The totalization depends on the operation mode. See chart in chapter IN 1 Totalization.			
	0	OFF	No totalization
	1	ON	Totalization is active

5.3. IN 1 Linearization

The linearization points of input 1 are defined in this menu. This menu is shown only, if the linearization is selected in 1 PROPERTIES.

Linearization description and examples are shown in the appendix.

P1(X) ... P24(X) X-coordinate of the linearization point. This value representing the display value which the unit show in the display without linearization.		
	-99999999	Smallest X-coordinate
	0	Default value
	+99999999	Largest X-coordinate

P1(Y) ... P24(Y) Y-coordinate of the linearization point This is the display value, which the unit should show in the display with linearization. E.g. P2(X) is replaced by P2(Y).		
	-99999999	Smallest Y-coordinate
	0	Default value
	+99999999	Largest Y-coordinate

5.4. IN 1 Totalization

The totalization function is defined in this menu. This menu will only be showed, if the totalization is active in Menu IN 1 PROPERTIES.

The totalizator depends on the operation mode. See in the following list.

Operation mode	Totalisation		
	INPUT 1 TOTAL	INPUT 2 TOTAL	LINKAGE TOTAL
SINGLE	active	→ 0	→ 0
DUAL	active	active	→ 0
IN1 + IN 2	active	active	Total 1 + Total 2
IN1 – IN 2	active	active	Total 1 – Total 2
IN1 x IN 2	active	active	→ 0
IN1 / IN 2	active	active	→ 0

TIME BASE

This parameter defines the time base of the totalization.
It defines the time interval between the recordings of data.

0	SECONDS	The current value is added to INPUT 1 TOTAL every second
1	MINUTES	The current value is added to INPUT 1 TOTAL every minute
2	HOURS	The current value is added to INPUT 1 TOTAL every hour
3	COMMAND	The current value is added to INPUT 1 TOTAL, when using the command (ADD TO TOTAL 1) for the operation function at the control input (see Command Menu)

DIVIDER

This parameter defines the divisor for the totalization.

0	1	No division
1	10	The result of the totalization is divided by 10
2	100	The result of the totalization is divided by 100
3	1000	The result of the totalization is divided by 1000

DECIMAL POINT

This value defines the position of the decimal point.

0	NO	No decimal point
1	0000000.0	Decimal point at the specified position
2	000000.00	Decimal point at the specified position
3	00000.000	Decimal point at the specified position
4	0000.0000	Decimal point at the specified position
5	000.00000	Decimal point at the specified position
6	00.000000	Decimal point at the specified position
7	0.0000000	Decimal point at the specified position

SCALE UNITS

This parameter defines the required engineering unit. This parameter does not affect the calculation of the display value. The number of decimal places must be defined with the parameter DECIMAL POINT. A list of available units can be found in Chapter 6.2 Appendix: Display of scale units.

5.5. IN 2 Properties

This menu defines the parameter for input 2.

CONFIGURATION

Configuration of input 2, see IN 1 Properties

START VALUE

Display value of input 2 at 0 V or 0/4 mA, see IN 1 Properties

END VALUE

Display value of input 2 at +10 V or 20 mA, see IN 1 Properties

DECIMAL POINT

Position of the decimal point, see IN 1 Properties

SCALE UNITS

The displayed units, see IN 1 Properties

SAMPLING TIME (S)

Sampling interval, see IN 1 Properties

AVERAGE FILTER

Selectable averages filter function, see IN 1 Properties.

OFFSET

Zero offset / tara, see IN 1 Properties

LINEARISATION

Linearization function, see IN 1 Properties.

TOTALIZATION

Totalization function, see IN 1 Properties.

5.6. IN 2 Linearization

The linearization points of input 2 are defined in this menu.

P1(X) ... P24(X)

X-coordinate of the linearization point, see IN 1 Linearization.

P1(Y) ... P24(Y)

Y-coordinate of the linearization point, see IN 1 Linearization.

5.7. IN 2 Totalization

The totalization function is defined in this menu.

TIME BASE

The time base of the totalization, see IN 1 Totalization

DIVIDER

The divisor for the totalization, see IN 1 Totalization.

DECIMAL POINT

Position of the decimal point, see IN 1 Totalization

SCALE UNITS

The displayed units, see IN 1 P Totalization

5.8. Linkage Properties

In this menu the parameters for the linked operation mode are defined. This menu is shown only, if in GENERAL MENU an operation mode (e.g. IN1 – IN2) with link was selected.

The parameters in Menu IN 1 PROPERTIES and IN 2 PROPERTIES have to be set, before using a linked operation mode. The result of the link can be scaled with the following parameters.

FACTOR		
This parameter defines the factor, the result of the link will be charged.		
	-99999999	Smallest value
	1	Default value
	99999999	Highest end value

DIVIDER		
This parameter defines the divider, the result of the link will be charged.		
	-99999999	Smallest end value
	1	Default value
	99999999	Highest end value

ADDITIVE VALUE		
This parameter defines the additive constant, the result of the link will be charged.		
	-99999999	Smallest end value
	0	Default value
	99999999	Highest end value

DECIMAL POINT		
This value defines the position of the decimal point.		
0	NO	No decimal point
1	000000.0	Decimal point at the specified position
2	000000.00	Decimal point at the specified position
3	00000.000	Decimal point at the specified position
4	0000.0000	Decimal point at the specified position
5	000.00000	Decimal point at the specified position
6	00.000000	Decimal point at the specified position
7	0.0000000	Decimal point at the specified position

SCALE UNITS		
This parameter defines the required engineering unit. This parameter does not affect the calculation of the display value. The number of decimal places must be defined with the parameter DECIMAL POINT. A list of available units can be found in Chapter 6.2 Appendix: Display of scale units.		

5.9. Preselection Values

This menu is used to set the preselection values or the switching points.
 The preselection values always refer to the SOURCE selected in the PRESELECTION x MENU.
 This function is only available for devices with option CO, CR, A0, AR or RL.

PRESELECTION 1_(Preselection / switching point 1)		
	-99999999	Smallest value
	1000	Default value
	+99999999	Highest value

PRESELECTION 2_(Preselection / switching point 2)		
	-99999999	Smallest value
	2000	Default value
	+99999999	Highest value

PRESELECTION 3 (Preselection / switching point 3)		
	-99999999	Smallest value
	3000	Default value
	+99999999	Highest value

PRESELECTION 4_(Preselection / switching point 4)		
	-99999999	Smallest value
	4000	Default value
	+99999999	Highest value

5.10. Preselection 1 Menu

Switching conditions for preselection 1. Output/ relay/ display switches under the following conditions.
 This function is only available for devices with option CO, CR, AO, AR or RL.

SOURCE 1		
This parameter defines the reference source for PRESELECTION 1		
0	INPUT 1	the reference source is input 1
1	INPUT 2	the reference source is input 2
2	LINKAGE 1 – 2	the reference source is the result of the linking of input1 and input 2
3	INPUT 1 TOTAL	the reference source is input 1 with totalization
4	INPUT 2 TOTAL	the reference source is input 2 with totalization
5	LINKAGE TOTAL	the reference source is the result of the linking of input1 and input 2 with totalization
6	IO LINK VALUE 1	the reference source is the process data out value 1 sent by the IO-Link master
7	IO LINK VALUE 2	the reference source is the process data out value 2 sent by the IO-Link master
8	MINIMUM VALUE 1	minimum value, the reference source is input 1
9	MAXIMUM VALUE 1	maximum value, the reference source is input 1
10	MINIMUM VALUE 2	minimum value, the reference source is input 2
11	MAXIMUM VALUE 2	maximum value, the reference source is input 2

MODE 1		
Switching conditions for preselection 1. Output/ relay/ display switches under the following conditions:		
0	 RESULT >= PRES 	Absolute value of the display value is greater or equal absolute value of PRESELECTION 1 With HYSTERESIS 1 not equal 0 the following switching condition is applied: Display value >= PRESELECTION 1 → ON, Display value < PRESELECTION 1 – HYSTERESIS 1 → OFF
1	 RESULT <= PRES 	Absolute value of the display value is less or equal absolute value of PRESELECTION 1 (start-up suppression (START UP DELAY) is advisable) With HYSTERESIS 1 not equal 0 the following switching condition is applied: Display value <= PRESELECTION 1 → ON, Display value > PRESELECTION 1 + HYSTERESIS 1 → OFF
2	 RESULT = PRES 	Absolute value of the display value is equal absolute value of PRESELECTION 1 A range (Preselection +/- ½ Hysteresis) can be defined and monitored in conjunction with the hysteresis. With HYSTERESIS 1 not equal 0 the following switching condition is applied: Display value > PRESELECTION 1 + ½ HYSTERESIS 1 → OFF, Display value < PRESELECTION 1 - ½ HYSTERESIS 1 → OFF
3	RESULT>=PRES	Display value is greater or equal PRESELECTION 1, e.g. overspeed With HYSTERESIS 1 not equal 0 the following switching condition is applied: Display value >= PRESELECTION 1 → ON, Display value < PRESELECTION 1 – HYSTERESIS 1 → OFF
4	RESULT<=PRES	Display value is less or equal PRESELECTION 1, e.g. underspeed (start-up suppression (START UP DELAY) is advisable) With HYSTERESIS 1 not equal 0 the following switching condition is applied: Display value <= PRESELECTION 1 → ON, Display value > PRESELECTION 1 + HYSTERESIS 1 → OFF
5	RESULT=PRES	Display value is equal PRESELECTION 1. A range (Preselection +/- ½ Hysteresis) can be defined and monitored in conjunction with the hysteresis. With HYSTERESIS 1 not equal 0 the following switching condition is applied: Display value > PRESELECTION 1 + ½ HYSTERESIS 1 → OFF, Display value < PRESELECTION 1 - ½ HYSTERESIS 1 → OFF
6	RES>=PRES-TRAIL	Trailing PRESELECTION 1: Display value is greater or equal PRESELECTION 2 – PRESELECTION 1, PRESELECTION 1 is the trailing preselection from PRESELECTION 2.
7	WIRE BREAK IN 1	Notification for device error - wire break detection input 1 (4...20mA) active.
8	WIRE BREAK IN 1	Notification for device error - wire break detection input 2 (4...20mA) active.
9	ERRORSET	Collective Notification

HYSTERESIS 1		
This parameter defines the switching hysteresis of the switch-off point for preselection 1		
	0	No switching hysteresis
	...	
	99999	Switching hysteresis of 99999

Continuation „Preselection 1 Menu“:

PULSE TIME 1 (S) Duration of output pulse for the switching condition of preselection 1		
	0,000	No output pulse (static signal)
	...	
	60,000	Pulse duration of 60 seconds

OUTPUT TARGET 1 Assignment of an output or relay for the switching condition of preselection 1. If more than one switching condition is assigned to one output / relay, the output is set when at least one switching condition is true		
	0 NO	No assignment
	1 CTRL OUT 1	Switching condition assigned to "Ctrl. Out 1"
	2 CTRL OUT 2	Switching condition assigned to "Ctrl. Out 2"
	3 CTRL OUT 3	Switching condition assigned to "Ctrl. Out 3"
	4 CTRL OUT 4	Switching condition assigned to "Ctrl. Out 4"
	5 RELAY 1	Switching condition assigned to "Rel. 1"
	6 RELAY 2	Switching condition assigned to "Rel. 2"

OUTPUT POLARITY 1 Polarity for the switching condition of preselection 1		
	0 ACTIVE HIGH	Switching condition is true → Active „HIGH“
	1 ACTIVE LOW	Switching condition is true → Active „LOW“

OUTPUT LOCK 1 Latch for the switching condition of preselection 1		
	0 NO	No latch for preselection
	1 YES	Latch for preselection (command LOCK RELEASE will clear latch)

START UP DELAY 1 (S) Start-up suppression for the switching condition of preselection 1. This adjustment is only valid for the switching condition $ \text{RESULT} \leq \text{PRES} $ or $\text{RESULT} \leq \text{PRES}$ START UP DELAY is set to this parameter, when the display value is ≤ 0 . The timer starts with a display value > 0 . The monitoring function remains deactivated until the set time has elapsed. (Start Up Delay 3 and 4 have an automatic start up suppression).		
	0.000	No start-up suppression
	...	
	60.000	Start-up suppression in seconds

EVENT COLOR 1 Event-depending change of the display color for the switching condition of preselection 1. EVENT COLOR 1 has the lowest priority. EVENT COLOR 2 ... 4 are allowed to overwrite this color change.		
	0 NO CHANGE	No color change.
	1 CHANGE TO RED	Color change to red
	2 CHANGE TO GREEN	Color change to green
	3 CHANGE TO YELLOW	Color change to yellow

5.11. Preselection 2 Menu

SOURCE 2

The reference source for PRESELECTION 2, see PRESELECTION 1 MENU. Depending on the current device setting and the device option, not every setting is visible.

MODE 2

Switching conditions for preselection 2, see PRESELECTION 1 MENU (expect trailing preselection)

			See chapter PRESELECTION 1 MENU
6	RES>=PRES-TRAIL		Trailing preselection 2: Display value is greater or equal to PRESELECTION 1 – PRESELECTION 2 PRESELECTION 2 is the trailing preselection from PRESELECTION 1.

HYSTERESIS 2

This parameter defines the switching hysteresis of the switch-off point for preselection 2.
See chapter PRESELECTION 1 MENU

PULSE TIME 2 (S)

Duration of output pulse for the switching condition of preselection 2.
See chapter PRESELECTION 1 MENU.

OUTPUT TARGET 2

Assignment of an output or relay for the switching condition of preselection 2.
See chapter PRESELECTION 1 MENU (expect default value).

			see PRESELECTION 1 MENU
2	CTRL OUT 2		Assignment of switching conditions at Ctrl. Out 2

OUTPUT POLARITY 2

Polarity for the switching condition of preselection 2.
See chapter PRESELECTION 1 MENU.

OUTPUT LOCK 2

Latch for the switching condition of preselection 2.
See chapter PRESELECTION 1 MENU.

START UP DELAY 2 (S)

Start-up suppression for the switching condition of preselection 2.
See chapter PRESELECTION 1 MENU.
(Start Up Delay 3 and 4 have an automatic start up suppression).

EVENT COLOR 2

Event-dependending change of the display colour for the switching condition of preselection 2.
See chapter PRESELECTION 1 MENU.

5.12. Preselection 3 Menu

SOURCE 3

The reference source for PRESELECTION 3, see PRESELECTION 1 MENU

MODE 3

Switching conditions for preselection 3, see PRESELECTION 1 MENU (expect trailing preselection)

			See chapter PRESELECTION 1 MENU
	6	RES>=PRES-TRAIL	Trailing preselection 3: Display value is greater or equal to PRESELECTION 4 – PRESELECTION 3 PRESELECTION 3 is the trailing preselection from PRESELECTION 4.

HYSTERESIS 3

This parameter defines the switching hysteresis of the switch-off point for preselection 3.
See chapter PRESELECTION 1 MENU.

PULSE TIME 3 (S)

Duration of output pulse for the switching condition of preselection 3.
See chapter PRESELECTION 1 MENU (except default value).

OUTPUT TARGET 3

Assignment of an output or relay for the switching condition of preselection 3.
See chapter PRESELECTION 1 MENU.

			see PRESELECTION 1 MENU
	3	CTRL OUT 3	Assignment of switching conditions at Ctrl. Out 3

OUTPUT POLARITY 3

Polarity for the switching condition of preselection 3.
See chapter PRESELECTION 1 MENU.

OUTPUT LOCK 3

Latch for the switching condition of preselection 3.
See chapter PRESELECTION 1 MENU.

START UP DELAY 3

Start-up suppression for the switching condition of preselection 3.
This adjustment is only valid for the switching condition $|\text{RESULT}| \leq |\text{PRES}|$ or $\text{RESULT} \leq$
Automatic start up suppression is activated, when the parameter is switched on and the display value is ≤ 0 . The monitoring function remains deactivated until the preset value / switching point is exceeded for the first time. (Start Up Delay 1 and 2 have a time-dependent start up suppression).

	0	OFF	No start-up suppression
	1	AUTO	Automatic start up suppression, until the preselection value / switching point is exceeded for the first time.

EVENT COLOR 3

Event-dependending change of the display colour for the switching condition of preselection 3.
See chapter PRESELECTION 1 MENU.

5.13. Preselection 4 Menu

SOURCE 4

The reference source for PRESELECTION 4, see PRESELECTION 1 MENU

MODE 4

Switching conditions for preselection 4, see PRESELECTION 1 MENU (expect trailing preselection)

			See chapter PRESELECTION 1 MENU
	6	RES>=PRES-TRAIL	Trailing preselection 4: Display value is greater or equal to PRESELECTION 3 – PRESELECTION 4 PRESELECTION 4 is the trailing preselection from PRESELECTION 3.

HYSTERESIS 4

This parameter defines the switching hysteresis of the switch-off point for preselection 4.
See chapter PRESELECTION 1 MENU.

PULSE TIME 4 (S)

Duration of output pulse for the switching condition of preselection 3.
See chapter PRESELECTION 1 MENU.

OUTPUT TARGET 4

Assignment of an output or relay for the switching condition of preselection 4.
See chapter PRESELECTION 1 MENU (except default value)..

			see PRESELECTION 1 MENU
	4	CTRL OUT 4	Assignment of switching conditions at Ctrl. Out 4

OUTPUT POLARITY 4

Polarity for the switching condition of preselection 4.
See chapter PRESELECTION 1 MENU.

OUTPUT LOCK 4

Latch for the switching condition of preselection 4.
See chapter PRESELECTION 1 MENU.

START UP DELAY 4

Start-up suppression for the switching condition of preselection 4, see PRESELECTION 3 MENU.
Automatic start up suppression is activated, when the parameter is switched on and the display value is <=0. The monitoring function remains deactivated until the preset value / switching point is exceeded for the first time. (Start Up Delay 1 and 2 have a time-dependent start up suppression).

	0	OFF	Automatic start up suppression,
	1	AUTO	until the preselection value / switching point is exceeded for the first time.

EVENT COLOR 4

Event-depending change of the display colour for the switching condition of preselection 4.
See chapter PRESELECTION 1 MENU.

5.14. Serial Menu

This menu defines the basic settings of serial interface.

This function is only available for devices with option CO, CR, AO, AR or AL

UNIT NUMBER		
This parameter defines serial device addresses. The addresses between 11 and 99 can be assigned to the devices. Addresses with zero are not allowed, there are used as broadcast addresses.		
	11	Smallest address
	...	
	99	Highest address

SERIAL BAUD RATE		
This parameter defines the serial baud rate		
0	9600	9600 baud
1	19200	19200 baud
2	38400	38400 baud

SERIAL FORMAT				
This parameter defines the bit data format.				
0	7-EVEN-1	7 data	Parity even	1 Stop
1	7-EVEN-2	7 data	Parity even	2 Stops
2	7-ODD-1	7 data	Parity odd	1 Stop
3	7-ODD-2	7 data	Parity odd	2 Stops
4	7-NONE-1	7 data	no Parity	1 Stop
5	7-NONE-2	7 data	no Parity	2 Stops
6	8-EVEN-1	8 data	Parity even	1 Stop
7	8-ODD-1	8 data	Parity odd	1 Stop
8	8-NONE-1	8 data	no Parity	1 Stop
9	8-NONE-2	8 data	no Parity	2 Stops

SERIAL INIT		
This parameter defines the baud rate for the initialization to the user interface OS6.0. With settings larger than 9600 the initialization time can be reduced.		
0	NO	Initialization with 9600 baud. Then the device operates with the value selected by the user.
1	YES	Initialization with the baud rate set by SERIAL BAUD RATE. Then the device operates with the value selected by the user.

Continuation „Serial Menu“:

SERIAL PROTOCOL														
Determines the sequence of characters send, when using the serial output for cyclic data transmission under time control (xxxxxxx = value SERIAL VALUE). Setting „1“ removes the unit address from the string which allows a slight faster transmission cycle.														
0	Transmission report = Unit Nr., +/-, data, LF, CR <table border="1" style="margin-left: auto; margin-right: auto;"> <tr> <td>1</td><td>1</td><td>+/-</td><td>X</td><td>X</td><td>X</td><td>X</td><td>X</td><td>X</td><td>X</td><td>LF</td><td>CR</td> </tr> </table>		1	1	+/-	X	X	X	X	X	X	X	LF	CR
1	1	+/-	X	X	X	X	X	X	X	LF	CR			
1	Transmission report = +/-, data, LF, CR <table border="1" style="margin-left: auto; margin-right: auto;"> <tr> <td>+/-</td><td>X</td><td>X</td><td>X</td><td>X</td><td>X</td><td>X</td><td>X</td><td>LF</td><td>CR</td> </tr> </table>		+/-	X	X	X	X	X	X	X	LF	CR		
+/-	X	X	X	X	X	X	X	LF	CR					

SERIAL TIMER (S)		
This register determines the cycle time in seconds for cycling transmission of SERIAL VALUE when using the serial output. (On a serial request, the cycling transmission is stopped for 20 s)		
0.000	All cyclic transmission is switched off. The unit will send data upon a serial request or with command SERIAL PRINT.	
...		
60.000	Cycle time in seconds.	

SERIAL VALUE			
This parameter defines the value to be transmitted.			
Setting	Code	Register contents	
0	:0	Value input 1	
1	:1	Value input 2	
2	:2	Result of the linking of input1 and input 2	
3	:3	Result totalizator 1	
4	:4	Result totalizator 2	
5	:5	Result of the linking of 1 and 2 with totalization	
6	:6	Minimum value input 1	
7	:7	Maximum value input 1	
8	:8	Minimum value input 2	
9	:9	Maximum value input 2	

MODBUS		
This parameter enables the Modbus protocol and determines the Modbus address. For details of the Modbus communication please refer to the additional manual Modbus_RTU		
0	Modbus disabled Serial interface is using Lecom protocol (Motrona default protocol)	
1 ... 247	Modbus enabled: Serial interface is using Modbus RTU protocol The set value is the Modbus address of the device.	

5.15. Analog Out Menu

This menu defines the basic settings of the analog output. This function is only available for devices with option A0 or AR.

ANALOG SOURCE		
This parameter defines the reference source for the Analog Output		
0	INPUT 1	the reference source is input 1
1	INPUT 2	the reference source is input 2
2	LINKAGE 1 – 2	the reference source is the result of the linking of input1 and input 2
3	INPUT 1 TOTAL	the reference source is input 1 with totalization
4	INPUT 2 TOTAL	the reference source is input 2 with totalization
5	LINKAGE TOTAL	the reference source is the result of the linking of input1 and input 2 with totalization
6	IO LINK VALUE 1	the reference source is the process data out value 1 sent by the IO-Link master
7	IO LINK VALUE 2	the reference source is the process data out value 2 sent by the IO-Link master
8	MINIMUM VALUE 1	minimum value, the reference source is input 1
9	MAXIMUM VALUE 1	maximum value, the reference source is input 1
10	MINIMUM VALUE 2	minimum value, the reference source is input 2
11	MAXIMUM VALUE 2	maximum value, the reference source is input 2

ANALOG FORMAT		
This parameter defines the output characteristics. The analogue output is proportional to the display value. With setting ANALOG FORMAT (-10 ... +10 V) the polarity of the analog output depends on the polarity of the display value.		
0	-10...10V	-10 ... +10 V
1	0...20MA	0 ... 20 mA
2	4...20MA	4 ... 20 mA

ANALOG START		
This parameter defines the start value of the analog conversion. This start value is corresponding to the display value for an analog output of 0 V or 0/4 mA.		
	-99999999	Smallest start value
	0	Default value
	+99999999	Highest start value

ANALOG END		
This parameter defines the end value of the analog conversion. This end value is corresponding to the display value for an analog output of (+/-) 10 V or 20mA.		
	-99999999	Smallest end value
	10000	Default Wert
	+99999999	Highest end value

Continuation „Analog Out Menu“:

ANALOG GAIN (%)

This parameter specifies the maximum conversion of the analog output in %.

e. g. 102.00 corresponds to a conversion of 10.2 V or 20.4 mA, when the ANALOG END value is reached.

e. g. 95.00 corresponds to a conversion of 9.5 V or 18 mA, when the ANALOG END value is reached..

	0,00	Smallest gain
	100,00	Default value
	110,00	Highest gain

ANALOG OFFSET (%)

This parameter defines the zero offset of the analog output.

e. g. 0.20 result in an offset of 0.02 V or 0.04 mA at ANALOG START value

	-99,99	Smallest offset
	0	Default value
	+99,99	Highest offset

5.16. Command Menu

INPUT 1 ACTION			
This parameter defines the function of the input "Ctrl. In 1". Depending on the current device setting and the device option, not every setting is visible.			
0	NO	No function	
1	TARA INPUT 1	Value of input 1 is stored as an OFFSET of input 1	(d)
2	TARA INPUT 2	Value of input 2 is stored as an OFFSET of input 2	(d)
3	TARA INPUT 1+2	Value of input 1 is stored as an OFFSET of input 1 Value of input 2 is stored as an OFFSET of input 2	(d)
4	RESET TOTAL 1	Value of totalizator 1 is reset to zero	(d) (s)
5	RESET TOTAL 2	Value of totalizator 2 is reset to zero	(d) (s)
6	RESET TOTAL 1+2	Value of totalizator 1 is reset to zero Value of totalizator 2 is reset to zero	(d) (s)
7	TEACH PRESEL. 1	Value (SOURCE 1) is stored as PRESELECTION 1	(d)
8	TEACH PRESEL. 2	Value (SOURCE 2) is stored as PRESELECTION 2	(d)
9	TEACH PRESEL. 3	Value (SOURCE 3) is stored as PRESELECTION 3	(d)
10	TEACH PRESEL. 4	Value (SOURCE 4) is stored as PRESELECTION 4	(d)
11	SCROLL DISPLAY	Display switching (see chapter Screen structure in operation)	(d)
12	RESET MIN/MAX	Reset the Min. / Max. values	(d) (s)
13	CLEAR LOOP TIME	N.A.	
14	ACTIVATE	N.A.	
15	STORE DATA	N.A.	
16	TESTPROGRAM	N.A.	
17	SET RED COLOR	Red display: Event-dependending change of the display colour by a switching condition is possible (see PRESELECTION 1...4 MENU)	(d)
18	SET GREEN COLOR	Green display: Event-dependending change of the display colour by a switching condition is possible (see PRESELECTION 1...4 MENU)	(d)
19	SET YELLOW COLOR	Yellow display: Event-dependending change of the display colour by a switching condition is possible (see PRESELECTION 1...4 MENU)	(d)
20	FREEZE	Freezing the display value	(s)
21	KEY LOCK	Key looked touch screen	(s)
22	LOCK RELEASE	No latch for preselection	(d)
23	SERIAL PRINT	Send serial data, see SERIAL VALUE	(d)
24	START PRESELECT	N.A.	
25	ADD TO TOTAL 1	Adds the current value of input 1 to INPUT 1 TOTAL	(d)
26	ADD TO TOTAL 2	Adds the current value of input 2 to INPUT 2 TOTAL	(d)
27	INC. BRIGHTNESS	Display brightness is increased	(d) (s)
28	DEC. BRIGHTNESS	Display brightness is reduced	(d) (s)

(s) = statistical characteristic (level evaluation)
INPUT CONFIG must be set to ACTIVE LOW/HIGH

(d) = dynamical characteristic (edge evaluation)
INPUT CONFIG must be set to RISING/FALLING EDGE

Continuation „**Command Menu**“:

INPUT 1 CONFIG		
This parameter defines the switching characteristics of the input "Ctrl. In 1".		
0	ACTIVE LOW	Active at „LOW“ (static)
1	ACTIVE HIGH	Active at „HIGH“ (static)
2	RISING EDGE	Activate at rising edge (dynamic)
3	FALLING EDGE	Activate at falling edge (dynamic)

INPUT 2 ACTION
This parameter defines the function of the input "Ctrl. In 2". See parameter INPUT 1 ACTION

INPUT 2 CONFIG
This parameter defines the switching characteristics of the input "Ctrl. In 2". See parameter INPUT 1 CONFIG.

INPUT 3 ACTION
This parameter defines the function of the input "Ctrl. In 3". See parameter INPUT 1 ACTION.

INPUT 3 CONFIG
This parameter defines the switching characteristics of the input "Ctrl. In 3". See parameter INPUT 1 CONFIG.

5.17. Display Menu

Parameter changes become active only after closing the menu selection.

START DISPLAY		
This parameter defines the start display after switching on the device.		
<u>Note:</u> The selected "window" must also be "activated", otherwise the next "activated" window will be used as the "start screen".		
0	SINGLE	Single-line display
1	DUAL	Two-line display
2	DUAL WITH UNIT	Two-line display with units
3	QUICKSTART	Quick start window for preselection values
3	LARGE	Large display
4	BARGRAPH	Bar graph display
5	MINIMUM/MAXIMUM	Display with actual / minimum / maximum values of input 1 and input 2

SHOW SINGLE WINDOW (Activating or deactivating the single-line status display)		
0	NO	Single-line status display is switched off.
1	YES	Single-line status display is switched on.

SOURCE SINGLE (Reference source for single-line display)		
Depending on the current device setting and the device option, not every setting is visible.		
0	INPUT 1	the reference source is input 1
1	INPUT 2	the reference source is input 2
2	LINKAGE 1 – 2	the reference source is the result of the linking of input1 and input 2
3	INPUT 1 TOTAL	the reference source is input 1 with totalization
4	INPUT 2 TOTAL	the reference source is input 2 with totalization
5	LINKAGE TOTAL	the reference source is the result of the linking of input1 and input 2 with totalization
6	IO LINK VALUE 1	the reference source is the process data out value 1 sent by the IO-Link master
7	IO LINK VALUE 2	the reference source is the process data out value 2 sent by the IO-Link master
8	MINIMUM VALUE 1	minimum value, the reference source is input 1
9	MAXIMUM VALUE 1	maximum value, the reference source is input 1
10	MINIMUM VALUE 2	minimum value, the reference source is input 2
11	MAXIMUM VALUE 2	maximum value, the reference source is input 2

SHOW DUAL WINDOW (Activating or deactivating of the dual display)		
0	NO	Both dual displays are switched off.
1	DUAL	Dual display without units is activated.
2	DUAL WITH UNIT	Dual display with units is activated.
3	BOTH WINDOWS	Both dual displays are activated.

SOURCE DUAL TOP (Reference source for two-line display, first line)		
Depending on the current device setting and the device option, not every setting is visible.		
0	INPUT 1	the reference source is input 1
1	INPUT 2	the reference source is input 2
2	LINKAGE 1 – 2	the reference source is the result of the linking of input1 and input 2
3	INPUT 1 TOTAL	the reference source is input 1 with totalization
4	INPUT 2 TOTAL	the reference source is input 2 with totalization
5	LINKAGE TOTAL	the reference source is the result of the linking of input1 and input 2 with totalization
6	IO LINK VALUE 1	the reference source is the process data out value 1 sent by the IO-Link master
7	IO LINK VALUE 2	the reference source is the process data out value 2 sent by the IO-Link master
8	MINIMUM VALUE 1	minimum value, the reference source is input 1
9	MAXIMUM VALUE 1	maximum value, the reference source is input 1
10	MINIMUM VALUE 2	minimum value, the reference source is input 2
11	MAXIMUM VALUE 2	maximum value, the reference source is input 2

SOURCE DUAL DOWN (Reference source for two-line display, second line) Depending on the current device setting and the device option, not every setting is visible.		
0	INPUT 1	the reference source is input 1
1	INPUT 2	the reference source is input 2
2	LINKAGE 1 – 2	the reference source is the result of the linking of input1 and input 2
3	INPUT 1 TOTAL	the reference source is input 1 with totalization
4	INPUT 2 TOTAL	the reference source is input 2 with totalization
5	LINKAGE TOTAL	the reference source is the result of the linking of input1 and input 2 with totalization
6	IO LINK VALUE 1	the reference source is the process data out value 1 sent by the IO-Link master
7	IO LINK VALUE 2	the reference source is the process data out value 2 sent by the IO-Link master
8	MINIMUM VALUE 1	minimum value, the reference source is input 1
9	MAXIMUM VALUE 1	maximum value, the reference source is input 1
10	MINIMUM VALUE 2	minimum value, the reference source is input 2
11	MAXIMUM VALUE 2	maximum value, the reference source is input 2

SHOW LARGE WINDOW (Activating or deactivating of the large display)		
0	NO	Large display is switched off.
1	YES	Large display is switched on.

SOURCE LARGE (Reference source for large display) Depending on the current device setting and the device option, not every setting is visible.		
0	INPUT 1	the reference source is input 1
1	INPUT 2	the reference source is input 2
2	LINKAGE 1 – 2	the reference source is the result of the linking of input1 and input 2
3	INPUT 1 TOTAL	the reference source is input 1 with totalization
4	INPUT 2 TOTAL	the reference source is input 2 with totalization
5	LINKAGE TOTAL	the reference source is the result of the linking of input1 and input 2 with totalization
6	IO LINK VALUE 1	the reference source is the process data out value 1 sent by the IO-Link master
7	IO LINK VALUE 2	the reference source is the process data out value 2 sent by the IO-Link master
8	MINIMUM VALUE 1	minimum value, the reference source is input 1
9	MAXIMUM VALUE 1	maximum value, the reference source is input 1
10	MINIMUM VALUE 2	minimum value, the reference source is input 2
11	MAXIMUM VALUE 2	maximum value, the reference source is input 2

LARGE DIVIDER (Splitting ratio of the large display) The display value for the large display can be divided accordingly by a splitting ratio.		
0	1:1	Large display with splitting ratio 1:1
1	1:10	Large display with splitting ratio 1:10
2	1:100	Large display with splitting ratio 1:100
3	1:1000	Large display with splitting ratio 1:1000

4	1:10000	Large display with splitting ratio 1:10000
---	---------	--------------------------------------------

SHOW GRAPH WINDOW (Activating or deactivating of the bar graph display)		
0	NO	Bar graph display is switched off.
1	YES	Bar graph display is switched on.

SOURCE GRAPH (Reference source for bar graph) Depending on the current device setting and the device option, not every setting is visible.		
0	INPUT 1	Reference source is input 1
1	INPUT 2	Reference source is input 2
2	LINKAGE 1 – 2	The reference source is the result of linking input 1 and input 2
3	INPUT 1 TOTAL	Reference source is input 1 with totalization
4	INPUT 2 TOTAL	Reference source is input 2 with totalization
5	LINKAGE TOTAL	Reference source is the result of linking input 1 and input 2 with totalization.
6	IO LINK VALUE 1	Reference source is the process data out value sent by the IO-Link master 1
7	IO LINK VALUE 2	Reference source is the process data out value sent by the IO-Link master 2
8	MINIMUM VALUE 1	Minimum value, reference source is input 1
9	MAXIMUM VALUE 1	Maximum value, reference source is input 1
10	MINIMUM VALUE 2	Minimum value, reference source is input 2
11	MAXIMUM VALUE 2	Maximum value, reference source is input 2

GRAPH TYPE (Display of the bar graph)		
0	UNIPOLAR RAMP	Ramp from left to right
1	BIPOLAR RAMP	Ramp from the center of the graph to the left or right
2	UNIPOLAR BEAM	Bar from left to right
3	BIPOLAR BEAM	Bar from the center of the graph to the left or right
4	CURSOR	Cursor

GRAPH LEFT END (Left end value of the bar graph display) This parameter defines the left end value of the bar graph display.		
	-99999	Smallest value
	0	Default value
	+99999	Highest Wert

GRAPH RIGHT END (Right end value of the bar graph display) This parameter defines the right end value of the bar graph display		
	0	Smallest value
	10000	Default value
	+99999	Highest value

SHOW PRESEL. WINDOW (Activating or deactivating the quick start display of the preselection values) Note:		
---------------------------------------------------------------------------------------------------------------------	--	--

This parameter is only visible for devices with the CO, CR, AO, AR or RL option.		
0	NO	Quick start display is switched off.
1	YES	Quick start display is switched on.

SHOW COMMAND WINDOW (Activation or deactivation of the quick start display or tare display)		
0	NO	Command display is switched off.
1	YES	Command display is switched on.

SHOW MIN/MAX WINDOW (Activating or deactivating the minimum/maximum display)		
0	NO	Minimum/maximum display is switched off.
1	YES	Minimum/Maximum display is switched on.

COLOR This parameter defines the display colour. Event-dependending change of the display colour by a switching condition is possible (see PRESELECTION 1...4 MENU) Event-dependending changes are only available for devices with option CO, CR, AO, AR or RL.		
0	RED	Red display
1	GREEN	Green display
2	YELLOW	Yellow display

BRIGHTNESS (%) This parameter defines the brightness of the display in percent		
	10	Min. brightness
	80	Default value
	100	Max. brightness

CONTRAST This parameter defines the viewing angle.		
	0	Viewing angle from top
	1	Viewing angle from centre
	2	Viewing angle from bottom

SCREEN SAVER (S) This parameter defines the time in seconds until the display is switched off, after the last touch action. A new touch action will activate the display again.		
	0	No switch off
	...	
	9999	Longest time to switch off

UP-DATE-TIME (S) This parameter defines the update time in seconds of the display only.		
	0,005	Shortest update time
	0,1	Default value

	9,999	Longest update time
--	--------------	---------------------

FONT

This parameter defines the setting of the font style.

	0	Standard
	1	Font 1

6. Appendix

6.1. Data readout via serial interface

All codes shown in the parameter SERIAL VALUE are available for serial readout by PC or PLC. The communication of the devices is based on the Drivecom protocol according to ISO 1745 or the Modbus RTU protocol. All protocol details can be found in the chapter "Modbus RTU Interface" in this manual.

To request for a data transmission you must send the following request string to the converter:

EOT	AD1	AD2	C1	C2	ENQ
-----	-----	-----	----	----	-----

EOT = control character (Hex 04)

AD1 = unit address, High Byte

AD2 = unit address, Low Byte

C1 = register code, High Byte

C2 = register code, Low Byte

ENQ = control character (Hex 05)

The following example shows the request string for readout of the actual input frequency of a monitor (Code:1) from a unit with unit address 11:

ASCII-Code:	EOT	1	1	:	1	ENQ
Hex-Code:	04	31	31	3A	31	05
Binary-Code:	0000 0100	0011 0001	0011 0001	0011 1010	0011 0001	0000 0101

After a correct request, the unit will respond:

STX	C1	C2	xxxxx	ETX	BCC
-----	----	----	-------	-----	-----

STX = control character (Hex 02)

C1 = register code, High Byte

C2 = register code, Low Byte

xxxxx = readout data

ETX = control character (Hex 03)

BCC = block check character

6.2. Modbus RTU Interface

The Modbus interface of the touchMatrix series is a standard Modbus RTU Slave and provides the following Modbus functions:

- Read Coils
- Write Single Coil
- Read Holding Registers
- Write Multiple Registers
- Diagnosis

For the operation of the interface module and the understanding of this manual basic knowledge in Modbus RTU communication is presupposed.

6.2.1. Parameter setting

Required parameter settings in WAY-AX "Serial menu":

UNIT NUMBER			
Not valid for Modbus communication (For setting of Modbus address see parameter "MODBUS")			

SERIAL BAUD RATE			
This parameter defines the serial baud rate			
	0	9600	9600 baud
	1	19200	19200 baud
	2	38400	38400 baud

SERIAL FORMAT					
This parameter defines the bit data format.					
	0	7-EVEN-1	Do not use with Modbus protocol		
	1	7-EVEN-2			
	2	7-ODD-1			
	3	7-ODD-2			
	4	7-NONE-1			
	5	7-NONE-2			
	6	8-EVEN-1	8 data bits	Parity even	1 stop bit
	7	8-ODD-1	8 data bits	Parity odd	1 stop bit
	8	8-NONE-1	Do not use with Modbus protocol		
	9	8-NONE-2	8 data bits	no Parity	2 stop bits

Continuation "Parameter setting"

SERIAL INIT
Not valid for Modbus communication

SERIAL PROTOCOL
Not valid for Modbus communication

SERIAL TIMER (S)
Not valid for Modbus communication

SERIAL VALUE
Not valid for Modbus communication

MODBUS	
This parameter enables the Modbus protocol and determines the Modbus address.	
0	Do not use for Modbus protocol (Modbus disabled)
1 ... 247	Modbus enabled: Serial interface is using Modbus RTU protocol The number set here determines the Modbus node address.

6.2.2. Modbus Communication

The following Modbus functions are available:

Read Holding Registers and Write Multiple Registers

With the functions "Read Holding Registers" and "Write Multiple Registers" it is possible to access all registers of the device.

All variables (actual data) and status registers are mapped to Modbus Holding Registers. However, as all registers of the device are 32-bit registers but Modbus Holding registers are only 16-bit registers, each register of the device requires two Holding registers. (For this reason, the use of Modbus function "Write Single Register" is not possible.)

It is only possible to access to one single register of the touchMATRIX device by each read or write operation, therefore the "Quantity (or number) of registers" in the Modbus request must always be 2.

Access to parameters

Holding Register 0x0000 / 0x0001 hex and following allow access to the device parameters.

The holding register numbers for a certain parameter can be calculated by the parameter # that can be found in the parameter table in the touchMatrix device manual:

Holding Register low = (parameter #) x 2
Holding Register high = (parameter #) x 2 + 1

Example:

Access to parameter # 51 "PRESELECTION 1" by Holding Register 0x0066 and 0x0067 hex.

Access to actual data

Holding Register 0x1000 / 0x1001 hex and following allow access to variables of the device (actual data registers):

Holding Register 0x1000 / 0x1001 hex → Actual data with serial Code ":0" (Display value)

Holding Register 0x1002 / 0x1003 hex → Actual data with serial Code ":1"

Holding Register 0x1004 / 0x1005 hex → Actual data with serial Code ":2"

Holding Register 0x1006 / 0x1007 hex → Actual data with serial Code ":3"

etc.

Access to status registers

Holding Register 0x2000 / 0x2001 hex and following allow access to status registers of the device:

Holding Register 0x2000 / 0x2001 hex → Output Status (Ctrl. Out status, read only)

Holding Register 0x2002 / 0x2003 hex → Serial Commands

Holding Register 0x2004 / 0x2005 hex → External Command (Ctrl. In status, read only)

Holding Register 0x2006 / 0x2007 hex → All Commands (read only)

Read Coils and Write Single Coil

With the functions "Read Coils" and "Write Single Coil" it is possible to read and set/reset single commands:

Coil number	Serial code of command	Command	
0	54	Reset / Set	Reset/Set Value
1	55	Freeze Display	Freeze actual display value
2	56	Touch Disable	Disable touch screen
3	57	Clear Lock	Loosen locking of all outputs / relay
4	58	Clear Min/Max	Reset of the min. / max. values
5	59	Serial Print (do not use with Modbus)	Sending of serial data
6	60	Teach Preset 1	Current display value is stored as PRESELECTION 1
7	61	Teach Preset 2	Current display value is stored as PRESELECTION 2
8	62	Teach Preset 3	Current display value is stored as PRESELECTION 3
9	63	Teach Preset 4	Current display value is stored as PRESELECTION 4
10	64	Scroll Display	Display switching (see display in operation mode)
11	65	Clear Loop Time	Release all latched switching conditions
12	66	Start Preselection	The preselection starts
13	67	Activate Data (not required with Modbus)	The data is activated.
14	68	Store to EEPROM	Store to EEPROM
15	69	Testprogram (do not use with Modbus)	Testprogram (do not use with Modbus)

6.2.3. Diagnostics

The device supports the diagnostics subfunction 00 "Return Query Data". Other diagnostics functions are not available.

6.3. Display of scale units

SCALE UNITS																																																																										
This parameter defines the required engineering unit. This parameter does not affect the calculation of the display value. The number of decimal places must be defined with the parameter DECIMAL POINT.																																																																										
0	V	Default																																																																								
1	mV																																																																									
2	A																																																																									
3	mA																																																																									
4	km/h																																																																									
5	mph																																																																									
6	feet/min																																																																									
7	inch/min																																																																									
8	g																																																																									
9	kg																																																																									
10	oz																																																																									
11	W																																																																									
12	kW																																																																									
13	VA																																																																									
14	mm																																																																									
15	cm																																																																									
16	m																																																																									
17	inch																																																																									
18	feet																																																																									
19	C																																																																									
20	F																																																																									
21	K																																																																									
22	1/sec																																																																									
23	1/min																																																																									
24	1/h																																																																									
25	gal/min																																																																									
26	Pa																																																																									
27	kPa																																																																									
28	%																																																																									
29	Edit Unit	<p>A customized unit with up to 16 digits can be edited using this parameter. Pressing the "OK" button opens the Edit Unit Menu. A unit can be created using the arrow keys. (by pressing and holding the arrow keys the characters scroll fast). The "OK" button saves the Edit Unit Menu. The "C" button closes the Edit Unit Menu.</p> <table border="1"> <tr> <td></td><td>!</td><td>"</td><td>#</td><td>\$</td><td>%</td><td>&</td><td>'</td><td>(</td><td>)</td><td>*</td><td>+</td><td>,</td><td>-</td><td>.</td><td>/</td><td>0</td><td>1</td> </tr> <tr> <td>8</td><td>9</td><td>:</td><td>;</td><td><</td><td>=</td><td>></td><td>?</td><td>@</td><td>A</td><td>B</td><td>C</td><td>D</td><td>E</td><td>F</td><td>G</td><td>H</td><td>I</td> </tr> <tr> <td>P</td><td>Q</td><td>R</td><td>S</td><td>T</td><td>U</td><td>V</td><td>W</td><td>X</td><td>Y</td><td>Z</td><td>[</td><td>\</td><td>]</td><td>^</td><td>_</td><td>`</td><td>a</td> </tr> <tr> <td>h</td><td>i</td><td>j</td><td>k</td><td>l</td><td>m</td><td>n</td><td>o</td><td>p</td><td>q</td><td>r</td><td>s</td><td>t</td><td>u</td><td>v</td><td>w</td><td>x</td><td>y</td> </tr> </table>		!	"	#	\$	%	&	'	()	*	+	,	-	.	/	0	1	8	9	:	;	<	=	>	?	@	A	B	C	D	E	F	G	H	I	P	Q	R	S	T	U	V	W	X	Y	Z	[\]	^	_	`	a	h	i	j	k	l	m	n	o	p	q	r	s	t	u	v	w	x	y
	!	"	#	\$	%	&	'	()	*	+	,	-	.	/	0	1																																																									
8	9	:	;	<	=	>	?	@	A	B	C	D	E	F	G	H	I																																																									
P	Q	R	S	T	U	V	W	X	Y	Z	[\]	^	_	`	a																																																									
h	i	j	k	l	m	n	o	p	q	r	s	t	u	v	w	x	y																																																									

6.4. Parameter / serial codes

6	Menu	Name	Serial Code	Value	Min	Max	Default
0	GENERAL MENU	OPERATIONAL MODE	00	0	0	5	0
1	GENERAL MENU	PIN PRESELECTION	01	0	0	9999	0
2	GENERAL MENU	PIN PARAMETER	02	0	0	9999	0
3	GENERAL MENU	BACK UP MEMORY	03	0	0	1	1
4	GENERAL MENU	FACTORY SETTINGS	04	0	0	1	0
5	GENERAL MENU	—	05	0	0	0	0
6	GENERAL MENU	—	06	0	0	0	0
7	GENERAL MENU	—	07	0	0	0	0
8	GENERAL MENU	—	08	0	0	0	0
9	IN 1 PROPERTIES	CONFIGURATION	09	0	0	2	0
10	IN 1 PROPERTIES	START VALUE	10	0	-99999999	99999999	0
11	IN 1 PROPERTIES	END VALUE	11	0	-99999999	99999999	10000
12	IN 1 PROPERTIES	DECIMAL POINT	12	0	0	7	3
13	IN 1 PROPERTIES	SCALE UNITS	13	0	0	29	0
14	IN 1 PROPERTIES	SAMPLING TIME (S)	14	0	1	60000	10
15	IN 1 PROPERTIES	AVERAGE FILTER	15	0	0	4	0
16	IN 1 PROPERTIES	OFFSET	16	0	-99999999	99999999	0
17	IN 1 PROPERTIES	LINEARIZATION	17	0	0	2	0
18	IN 1 PROPERTIES	TOTALIZATION	18	0	0	1	0
19	IN 1 PROPERTIES	—	19	0	0	0	0
20	IN 1 PROPERTIES	—	20	0	0	0	0
21	IN 1 PROPERTIES	—	21	0	0	0	0
22	IN 1 LINEARIZATION	P1(X)	A0	0	-99999999	99999999	0
23	IN 1 LINEARIZATION	P1(Y)	A1	0	-99999999	99999999	0
24	IN 1 LINEARIZATION	P2(X)	A2	0	-99999999	99999999	0
25	IN 1 LINEARIZATION	P2(Y)	A3	0	-99999999	99999999	0
26	IN 1 LINEARIZATION	P3(X)	A4	0	-99999999	99999999	0
27	IN 1 LINEARIZATION	P3(Y)	A5	0	-99999999	99999999	0
28	IN 1 LINEARIZATION	P4(X)	A6	0	-99999999	99999999	0
29	IN 1 LINEARIZATION	P4(Y)	A7	0	-99999999	99999999	0
30	IN 1 LINEARIZATION	P5(X)	A8	0	-99999999	99999999	0
31	IN 1 LINEARIZATION	P5(Y)	A9	0	-99999999	99999999	0
32	IN 1 LINEARIZATION	P6(X)	B0	0	-99999999	99999999	0
33	IN 1 LINEARIZATION	P6(Y)	B1	0	-99999999	99999999	0
34	IN 1 LINEARIZATION	P7(X)	B2	0	-99999999	99999999	0
35	IN 1 LINEARIZATION	P7(Y)	B3	0	-99999999	99999999	0
36	IN 1 LINEARIZATION	P8(X)	B4	0	-99999999	99999999	0
37	IN 1 LINEARIZATION	P8(Y)	B5	0	-99999999	99999999	0
38	IN 1 LINEARIZATION	P9(X)	B6	0	-99999999	99999999	0
39	IN 1 LINEARIZATION	P9(Y)	B7	0	-99999999	99999999	0
40	IN 1 LINEARIZATION	P10(X)	B8	0	-99999999	99999999	0
41	IN 1 LINEARIZATION	P10(Y)	B9	0	-99999999	99999999	0
42	IN 1 LINEARIZATION	P11(X)	C0	0	-99999999	99999999	0
43	IN 1 LINEARIZATION	P11(Y)	C1	0	-99999999	99999999	0
44	IN 1 LINEARIZATION	P12(X)	C2	0	-99999999	99999999	0
45	IN 1 LINEARIZATION	P12(Y)	C3	0	-99999999	99999999	0

Continuation „Parameter list“:

#	Menu	Name	Serial Code	Value	Min	Max	Default
46	IN 1 LINEARIZATION	P13(X)	C4	0	-99999999	99999999	0
47	IN 1 LINEARIZATION	P13(Y)	C5	0	-99999999	99999999	0
48	IN 1 LINEARIZATION	P14(X)	C6	0	-99999999	99999999	0
49	IN 1 LINEARIZATION	P14(Y)	C7	0	-99999999	99999999	0
50	IN 1 LINEARIZATION	P15(X)	C8	0	-99999999	99999999	0
51	IN 1 LINEARIZATION	P15(Y)	C9	0	-99999999	99999999	0
52	IN 1 LINEARIZATION	P16(X)	D0	0	-99999999	99999999	0
53	IN 1 LINEARIZATION	P16(Y)	D1	0	-99999999	99999999	0
54	IN 1 LINEARIZATION	P17(X)	D2	0	-99999999	99999999	0
55	IN 1 LINEARIZATION	P17(Y)	D3	0	-99999999	99999999	0
56	IN 1 LINEARIZATION	P18(X)	D4	0	-99999999	99999999	0
57	IN 1 LINEARIZATION	P18(Y)	D5	0	-99999999	99999999	0
58	IN 1 LINEARIZATION	P19(X)	D6	0	-99999999	99999999	0
59	IN 1 LINEARIZATION	P19(Y)	D7	0	-99999999	99999999	0
60	IN 1 LINEARIZATION	P20(X)	D8	0	-99999999	99999999	0
61	IN 1 LINEARIZATION	P20(Y)	D9	0	-99999999	99999999	0
62	IN 1 LINEARIZATION	P21(X)	E0	0	-99999999	99999999	0
63	IN 1 LINEARIZATION	P21(Y)	E1	0	-99999999	99999999	0
64	IN 1 LINEARIZATION	P22(X)	E2	0	-99999999	99999999	0
65	IN 1 LINEARIZATION	P22(Y)	E3	0	-99999999	99999999	0
66	IN 1 LINEARIZATION	P23(X)	E4	0	-99999999	99999999	0
67	IN 1 LINEARIZATION	P23(Y)	E5	0	-99999999	99999999	0
68	IN 1 LINEARIZATION	P24(X)	E6	0	-99999999	99999999	0
69	IN 1 LINEARIZATION	P24(Y)	E7	0	-99999999	99999999	0
70	IN 1 TOTALIZATION	BASE	E8	0	0	3	0
71	IN 1 TOTALIZATION	DIVIDER	E9	0	0	3	0
72	IN 1 TOTALIZATION	DECIMAL POINT	F0	0	0	7	0
73	IN 1 TOTALIZATION	SCALE UNITS	F1	0	0	29	0
74	IN 1 TOTALIZATION	—	F2	0	0	0	0
75	IN 1 TOTALIZATION	—	F3	0	0	0	0
76	IN 1 TOTALIZATION	—	F4	0	0	0	0
77	IN 2 PROPERTIES	CONFIGURATION	F5	0	0	2	0
78	IN 2 PROPERTIES	START VALUE	F6	0	-99999999	99999999	0
79	IN 2 PROPERTIES	END VALUE	F7	0	-99999999	99999999	10000
80	IN 2 PROPERTIES	DECIMAL POINT	F8	0	0	7	3
81	IN 2 PROPERTIES	SCALE UNITS	F9	0	0	29	0
82	IN 2 PROPERTIES	SAMPLING TIME (S)	G0	0	1	60000	10
83	IN 2 PROPERTIES	AVERAGE FILTER	G1	0	0	4	0
84	IN 2 PROPERTIES	OFFSET	G2	0	-99999999	99999999	0
85	IN 2 PROPERTIES	LINEARIZATION	G3	0	0	2	0
86	IN 2 PROPERTIES	TOTALIZATION	G4	0	0	1	0
87	IN 2 PROPERTIES	—	G5	0	0	0	0
88	IN 2 PROPERTIES	—	G6	0	0	0	0
89	IN 2 PROPERTIES	—	G7	0	0	0	0

Continuation „Parameter“:

#	Menu	Name	Serial Code	Value	Min	Max	Default
90	IN 2 LINEARIZATION	P1(X)	G8	0	-99999999	99999999	0
91	IN 2 LINEARIZATION	P1(Y)	G9	0	-99999999	99999999	0
92	IN 2 LINEARIZATION	P2(X)	H0	0	-99999999	99999999	0
93	IN 2 LINEARIZATION	P2(Y)	H1	0	-99999999	99999999	0
94	IN 2 LINEARIZATION	P3(X)	H2	0	-99999999	99999999	0
95	IN 2 LINEARIZATION	P3(Y)	H3	0	-99999999	99999999	0
96	IN 2 LINEARIZATION	P4(X)	H4	0	-99999999	99999999	0
97	IN 2 LINEARIZATION	P4(Y)	H5	0	-99999999	99999999	0
98	IN 2 LINEARIZATION	P5(X)	H6	0	-99999999	99999999	0
99	IN 2 LINEARIZATION	P5(Y)	H7	0	-99999999	99999999	0
100	IN 2 LINEARIZATION	P6(X)	H8	0	-99999999	99999999	0
101	IN 2 LINEARIZATION	P6(Y)	H9	0	-99999999	99999999	0
102	IN 2 LINEARIZATION	P7(X)	I0	0	-99999999	99999999	0
103	IN 2 LINEARIZATION	P7(Y)	I1	0	-99999999	99999999	0
104	IN 2 LINEARIZATION	P8(X)	I2	0	-99999999	99999999	0
105	IN 2 LINEARIZATION	P8(Y)	I3	0	-99999999	99999999	0
106	IN 2 LINEARIZATION	P9(X)	I4	0	-99999999	99999999	0
107	IN 2 LINEARIZATION	P9(Y)	I5	0	-99999999	99999999	0
108	IN 2 LINEARIZATION	P10(X)	I6	0	-99999999	99999999	0
109	IN 2 LINEARIZATION	P10(Y)	I7	0	-99999999	99999999	0
110	IN 2 LINEARIZATION	P11(X)	I8	0	-99999999	99999999	0
111	IN 2 LINEARIZATION	P11(Y)	I9	0	-99999999	99999999	0
112	IN 2 LINEARIZATION	P12(X)	J0	0	-99999999	99999999	0
113	IN 2 LINEARIZATION	P12(Y)	J1	0	-99999999	99999999	0
114	IN 2 LINEARIZATION	P13(X)	J2	0	-99999999	99999999	0
115	IN 2 LINEARIZATION	P13(Y)	J3	0	-99999999	99999999	0
116	IN 2 LINEARIZATION	P14(X)	J4	0	-99999999	99999999	0
117	IN 2 LINEARIZATION	P14(Y)	J5	0	-99999999	99999999	0
118	IN 2 LINEARIZATION	P15(X)	J6	0	-99999999	99999999	0
119	IN 2 LINEARIZATION	P15(Y)	J7	0	-99999999	99999999	0
120	IN 2 LINEARIZATION	P16(X)	J8	0	-99999999	99999999	0
121	IN 2 LINEARIZATION	P16(Y)	J9	0	-99999999	99999999	0
122	IN 2 LINEARIZATION	P17(X)	K0	0	-99999999	99999999	0
123	IN 2 LINEARIZATION	P17(Y)	K1	0	-99999999	99999999	0
124	IN 2 LINEARIZATION	P18(X)	K2	0	-99999999	99999999	0
125	IN 2 LINEARIZATION	P18(Y)	K3	0	-99999999	99999999	0
126	IN 2 LINEARIZATION	P19(X)	K4	0	-99999999	99999999	0
127	IN 2 LINEARIZATION	P19(Y)	K5	0	-99999999	99999999	0
128	IN 2 LINEARIZATION	P20(X)	K6	0	-99999999	99999999	0
129	IN 2 LINEARIZATION	P20(Y)	K7	0	-99999999	99999999	0
130	IN 2 LINEARIZATION	P21(X)	K8	0	-99999999	99999999	0
131	IN 2 LINEARIZATION	P21(Y)	K9	0	-99999999	99999999	0
132	IN 2 LINEARIZATION	P22(X)	L0	0	-99999999	99999999	0
133	IN 2 LINEARIZATION	P22(Y)	L1	0	-99999999	99999999	0
134	IN 2 LINEARIZATION	P23(X)	L2	0	-99999999	99999999	0
135	IN 2 LINEARIZATION	P23(Y)	L3	0	-99999999	99999999	0

Continuation „Parameter“:

#	Menu	Name	Serial Code	Value	Min	Max	Default
136	IN 2 LINEARIZATION	P24(X)	L4	0	-99999999	99999999	0
137	IN 2 LINEARIZATION	P24(Y)	L5	0	-99999999	99999999	0
138	IN 2 TOTALIZATION	BASE	L6	0	0	3	0
139	IN 2 TOTALIZATION	DIVIDER	L7	0	0	3	0
140	IN 2 TOTALIZATION	DECIMAL POINT	L8	0	0	7	0
141	IN 2 TOTALIZATION	SCALE UNITS	L9	0	0	29	0
142	IN 2 TOTALIZATION	___	M0	0	0	0	0
143	IN 2 TOTALIZATION	___	M1	0	0	0	0
144	IN 2 TOTALIZATION	___	M2	0	0	0	0
145	LINKAGE PROPERTIES	FACTOR	M3	0	-99999999	99999999	1
146	LINKAGE PROPERTIES	DIVIDER	M4	0	-99999999	99999999	1
147	LINKAGE PROPERTIES	ADDITIVE VALUE	M5	0	-99999999	99999999	0
148	LINKAGE PROPERTIES	DECIMAL POINT	M6	0	0	7	0
149	LINKAGE PROPERTIES	SCALE UNITS	M7	0	0	29	0
150	LINKAGE PROPERTIES	___	M8	0	0	0	0
151	LINKAGE PROPERTIES	___	M9	0	0	0	0
152	LINKAGE PROPERTIES	___	N0	0	0	0	0
153	IO LINK PROPERTIES	IN1 FACTOR	N1	0	-99999999	99999999	1
154	IO LINK PROPERTIES	IN1 DEVIDER	N2	0	-99999999	99999999	1
155	IO LINK PROPERTIES	IN1 ADDITIVE VALUE	N3	0	-99999999	99999999	0
156	IO LINK PROPERTIES	IN1 DECIMAL POINT	N4	0	0	7	0
157	IO LINK PROPERTIES	IN1 SCALE UNITS	N5	0	0	29	0
158	IO LINK PROPERTIES	IN2 FACTOR	N6	0	-99999999	99999999	1
159	IO LINK PROPERTIES	IN2 DEVIDER	N7	0	-99999999	99999999	1
160	IO LINK PROPERTIES	IN2 ADDITIVE VALUE	N8	0	-99999999	99999999	0
161	IO LINK PROPERTIES	IN2 DECIMAL POINT	N9	0	0	7	0
162	IO LINK PROPERTIES	IN2 SCALE UNITS	O0	0	0	29	0
163	IO LINK PROPERTIES	___	O1	0	0	0	0
164	IO LINK PROPERTIES	___	O2	0	0	0	0
165	IO LINK PROPERTIES	___	O3	0	0	0	0
166	IO LINK PROPERTIES	___	O4	0	0	0	0
167	PRESELECTION VALUES	PRESELECTION 1	O5	0	-99999999	99999999	1000
168	PRESELECTION VALUES	PRESELECTION 2	O6	0	-99999999	99999999	2000
169	PRESELECTION VALUES	PRESELECTION 3	O7	0	-99999999	99999999	3000
170	PRESELECTION VALUES	PRESELECTION 4	O8	0	-99999999	99999999	4000
171	PRESELECTION VALUES	___	O9	0	0	0	0
172	PRESELECTION VALUES	___	P0	0	0	0	0
173	PRESELECTION 1 MENU	SOURCE 1	P1	0	0	11	0
174	PRESELECTION 1 MENU	MODE 1	P2	0	0	9	0
175	PRESELECTION 1 MENU	HYSTERESIS 1	P3	0	0	99999	0
176	PRESELECTION 1 MENU	PULSE TIME 1	P4	0	0	60000	0
177	PRESELECTION 1 MENU	OUTPUT TARGET 1	P5	0	0	6	1
178	PRESELECTION 1 MENU	OUTPUT POLARITY 1	P6	0	0	1	0
179	PRESELECTION 1 MENU	OUTPUT LOCK 1	P7	0	0	1	0
180	PRESELECTION 1 MENU	START UP DELAY 1	P8	0	0	60000	0
181	PRESELECTION 1 MENU	EVENT COLOR 1	P9	0	0	3	0

Continuation „Parameter“:

#	Menu	Name	Serial Code	Value	Min	Max	Default
182	PRESELECTION 1 MENU	---	Q0	0	0	0	0
183	PRESELECTION 1 MENU	---	Q1	0	0	0	0
184	PRESELECTION 2 MENU	SOURCE 2	Q2	0	0	11	0
185	PRESELECTION 2 MENU	MODE 2	Q3	0	0	9	0
186	PRESELECTION 2 MENU	HYSTERESIS 2	Q4	0	0	99999	0
187	PRESELECTION 2 MENU	PULSE TIME 2	Q5	0	0	60000	0
188	PRESELECTION 2 MENU	OUTPUT TARGET 2	Q6	0	0	6	2
189	PRESELECTION 2 MENU	OUTPUT POLARITY 2	Q7	0	0	1	0
190	PRESELECTION 2 MENU	OUTPUT LOCK 2	Q8	0	0	1	0
191	PRESELECTION 2 MENU	START UP DELAY 2	Q9	0	0	60000	0
192	PRESELECTION 2 MENU	EVENT COLOR 2	R0	0	0	3	0
193	PRESELECTION 2 MENU	---	R1	0	0	0	0
194	PRESELECTION 2 MENU	---	R2	0	0	0	0
195	PRESELECTION 3 MENU	SOURCE 3	R3	0	0	11	0
196	PRESELECTION 3 MENU	MODE 3	R4	0	0	9	0
197	PRESELECTION 3 MENU	HYSTERESIS 3	R5	0	0	99999	0
198	PRESELECTION 3 MENU	PULSE TIME 3	R6	0	0	60000	0
199	PRESELECTION 3 MENU	OUTPUT TARGET 3	R7	0	0	6	3
200	PRESELECTION 3 MENU	OUTPUT POLARITY 3	R8	0	0	1	0
201	PRESELECTION 3 MENU	OUTPUT LOCK 3	R9	0	0	1	0
202	PRESELECTION 3 MENU	START UP DELAY 3	S0	0	0	1	0
203	PRESELECTION 3 MENU	EVENT COLOR 3	S1	0	0	3	0
204	PRESELECTION 3 MENU	---	S2	0	0	0	0
205	PRESELECTION 3 MENU	---	S3	0	0	0	0
206	PRESELECTION 4 MENU	SOURCE 4	S4	0	0	11	0
207	PRESELECTION 4 MENU	MODE 4	S5	0	0	8	0
208	PRESELECTION 4 MENU	HYSTERESIS 4	S6	0	0	99999	0
209	PRESELECTION 4 MENU	PULSE TIME 4	S7	0	0	60000	0
210	PRESELECTION 4 MENU	OUTPUT TARGET 4	S8	0	0	6	4
211	PRESELECTION 4 MENU	OUTPUT POLARITY 4	S9	0	0	1	0
212	PRESELECTION 4 MENU	OUTPUT LOCK 4	T0	0	0	1	0
213	PRESELECTION 4 MENU	START UP DELAY 4	T1	0	0	1	0
214	PRESELECTION 4 MENU	EVENT COLOR 4	T2	0	0	3	0
215	PRESELECTION 4 MENU	---	T3	0	0	0	0
216	PRESELECTION 4 MENU	---	T4	0	0	0	0
217	SERIAL MENU	UNIT NUMBER	90	0	11	99	11
218	SERIAL MENU	SERIAL BAUD RATE	91	0	0	2	0
219	SERIAL MENU	SERIAL FORMAT	92	0	0	9	0
220	SERIAL MENU	SERIAL INIT	9~	0	0	1	0
221	SERIAL MENU	SERIAL PROTOCOL	T5	0	0	1	0
222	SERIAL MENU	SERIAL TIMER	T6	0	0	60000	0
223	SERIAL MENU	SERIAL VALUE	T7	0	0	9	0
224	SERIAL MENU	MODBUS	T8	0	0	0	247
225	SERIAL MENU	---	T9	0	0	0	0

Continuation „Parameter“

#	Menu	Name	Serial Code	Value	Min	Max	Default
226	ANALOG OUT MENU	ANALOG SOURCE	U0	0	0	11	0
227	ANALOG OUT MENU	ANALOG FORMAT	U1	0	0	2	0
228	ANALOG OUT MENU	ANALOG START	U2	0	-99999999	99999999	0
229	ANALOG OUT MENU	ANALOG END	U3	0	-99999999	99999999	10000
230	ANALOG OUT MENU	ANALOG GAIN %	U4	0	0	11000	10000
231	ANALOG OUT MENU	ANALOG OFFSET %	U5	0	-9999	9999	0
232	ANALOG OUT MENU	___	U6	0	0	0	0
233	ANALOG OUT MENU	___	U7	0	0	0	0
234	COMMAND MENU	INPUT 1 ACTION	U8	0	0	28	0
235	COMMAND MENU	INPUT 1 CONFIG.	U9	0	0	3	2
236	COMMAND MENU	INPUT 2 ACTION	V0	0	0	28	0
237	COMMAND MENU	INPUT 2 CONFIG.	V1	0	0	3	2
238	COMMAND MENU	INPUT 3 ACTION	V2	0	0	28	0
239	COMMAND MENU	INPUT 3 CONFIG.	V3	0	0	3	2
240	COMMAND MENU	___	V4	0	0	0	0
241	COMMAND MENU	___	V5	0	0	0	0
242	COMMAND MENU	___	V6	0	0	0	0
243	COMMAND MENU	___	V7	0	0	0	0
244	DISPLAY MENU	START DISPLAY	V8	0	0	5	0
245	DISPLAY MENU	SHOW SINGLE WINDOW	V9	0	0	1	1
246	DISPLAY MENU	SOURCE SINGLE	W0	0	0	11	0
247	DISPLAY MENU	SHOW DUAL WINDOW	W1	0	0	3	3
248	DISPLAY MENU	SOURCE DUAL TOP	W2	0	0	11	0
249	DISPLAY MENU	SOURCE DUAL DOWN	W3	0	0	11	1
250	DISPLAY MENU	SHOW LARGE WINDOW	W4	0	0	1	0
251	DISPLAY MENU	SOURCE LARGE	W5	0	0	11	0
252	DISPLAY MENU	LARGE DIVIDER	W6	0	0	4	0
253	DISPLAY MENU	SHOW GRAPH WINDOW	W7	0	0	1	0
254	DISPLAY MENU	SOURCE GRAPH	W8	0	0	11	0
255	DISPLAY MENU	GRAPH TYPE	W9	0	0	4	0
256	DISPLAY MENU	GRAPH LEFT END	a 0	0	-99999	99999	0
257	DISPLAY MENU	GRAPH RIGHT END	a 1	0	0	99999	10000
258	DISPLAY MENU	SHOW PRESEL. WINDOW	a 2	0	0	1	0
259	DISPLAY MENU	SHOW COMMAND WINDOW	a 3	0	0	1	0
260	DISPLAY MENU	SHOW MIN/MAX WINDOW	a 4	0	0	1	0
261	DISPLAY MENU	COLOR	a 5	0	0	2	0
262	DISPLAY MENU	BRIGHTNESS	a 6	0	10	100	80
263	DISPLAY MENU	CONTRAST	a 7	0	0	2	1
264	DISPLAY MENU	SCREEN SAVER	a 8	0	0	9999	0
265	DISPLAY MENU	UP-DATE-TIME	a 9	0	5	9999	100
266	DISPLAY MENU	FONT	b 0	0	0	1	0

Serial codes of commands:

Serial Code	Command
54	TARA INPUT 1
55	TARA INPUT 2
56	TARA INPUT 1 + 2
57	RESET TOTAL 1
58	RESET TOTAL 2
59	RESET TOTAL LINKAGE
60	TEACH PRESELECTION 1
61	TEACH PRESELECTION 2
62	TEACH PRESELECTION 3
63	TEACH PRESELECTION 4
64	SCROLL DISPLAY
65	CLEAR MIN/MAX VALUES
66	CLEAR LOOP TIME
67	ACTIVATE DATA
68	STORE EEPROM
69	TESTPROGRAMM

Unit Variables:

Serial Code	AX350
:0	Result[INPUT_1];
:1	Result[INPUT_2];
:2	Result[LINKAGE_1_2];
:3	Result[TOTAL_1];
:4	Result[TOTAL_2];
:5	Result[TOTAL_LINKAGE];
:6	Minimum_Value_1;
:7	Maximum_Value_1;
:8	Minimum_Value_2;
:9	Maximum_Value_2;
;0	Error_Status;
;1	0;
;2	SDADC_IN1_Voltage;
;3	SDADC_IN1_Current;
;4	SDADC_IN2_Voltage;
;5	SDADC_IN2_Current;

6.5. Linearization

The linearization function of this unit allows converting a linear input signal into a non-linear developing (or vice versa). There are 24 programmable x/y coordinates available for input 1 and input 2, which can be set in any desired distance over the full conversion range. Between two coordinates, the unit uses linear interpolation. Therefore, it is advisable to use more coordinates in a range with strong curves and only a few coordinates where the curvature is less.

To specify an individual linearization curve, the parameter LINEARISATION MODE must be set to either 1 QUADRANT or 4 QUADRANT (see following diagram).

The parameters P1(X) to P24(X) are used to specify the coordinates on the x-axis. These are the measuring values that the unit normally would generate according to the actual input signal.

Now enter the attached values to parameter P1(Y) to P24(Y). These are the values that the unit will generate instead of the x- values, i.e. P5(Y) replaces P5(X) etc.

The X-Coordinates must use continuously increasing settings, i.e. P1(X) must have the lowest and P24(X) must have the highest setting. If the measured value is bigger than the last defined X-value, the corresponding Y-value is displayed.

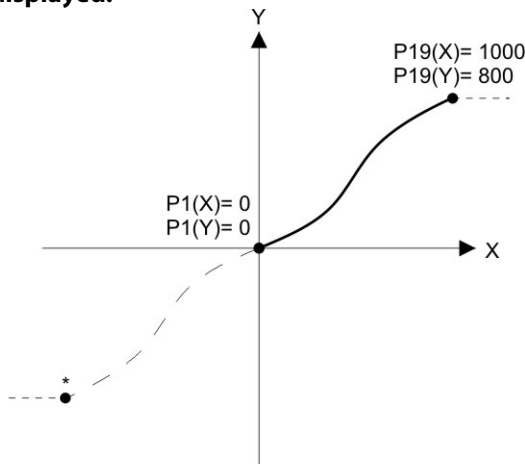

Example: Linearization Mode: 1 Quadrant
* Linearization is point symmetric to 1. Quadrant

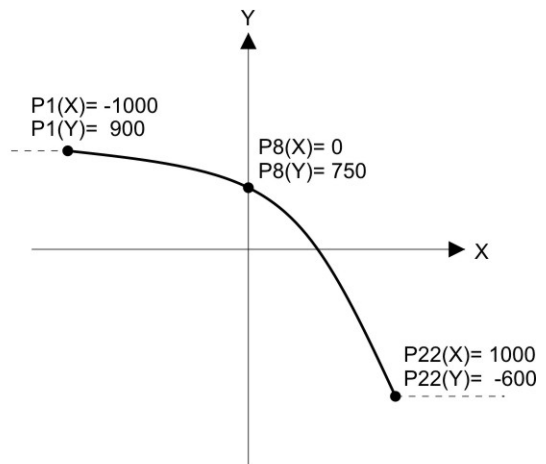

Example: Linearization Mode: 4 Quadrant

Mode: 1 Quadrant:

P1(X) must be set to zero. Linearization is only defined in the positive range and the negative range will be mirrored symmetric to central point.

Mode: 4 Quadrant:

P1(X) can also be set to a negative value. If the measured value is smaller than P1(X), P1(Y) is displayed.

Application Example:

We like to display the filling quantity (volume) of a tank as shown below, with use of a pressure sensor mounted to the bottom of the tank. With this application the analogue pressure signal is proportional to the filling level, but not to the filling quantity.

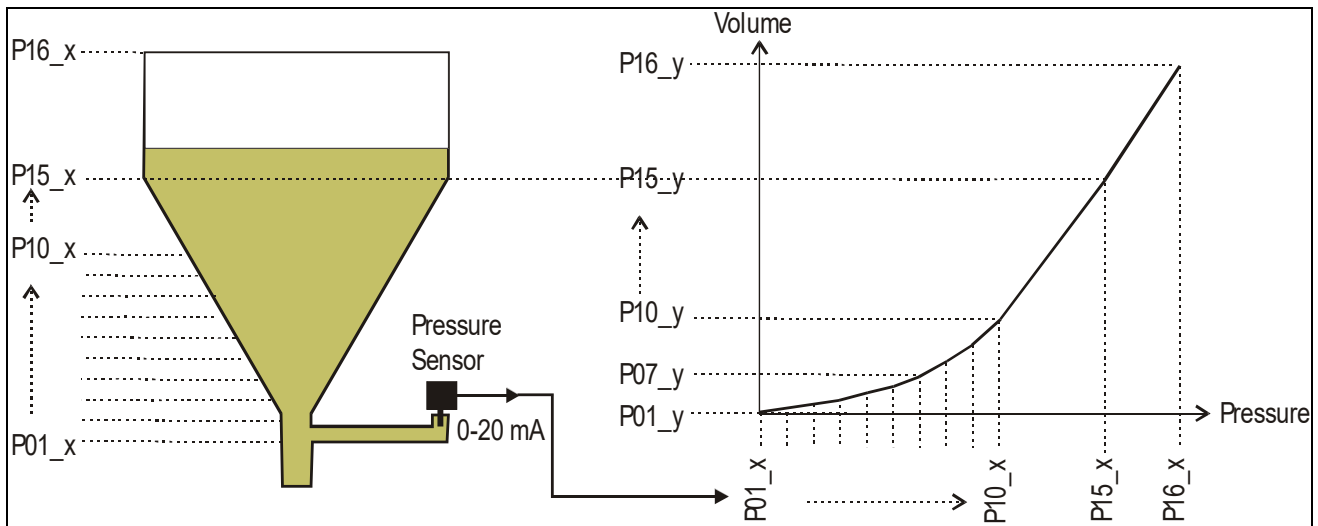

To solve the problem, we divide the non-linear part of the tank into 14 parts. We enter the expected display values of the pressure sensor to registers P01_x to P15_x.

For the linear part of the tank it is sufficient to store the final pressure value to register P16_x.

Now we can easily calculate the appropriate filling quantities and enter these values to the registers P01_y to P16_y.

6.6. Dimensions

Dimension in mm [inch]

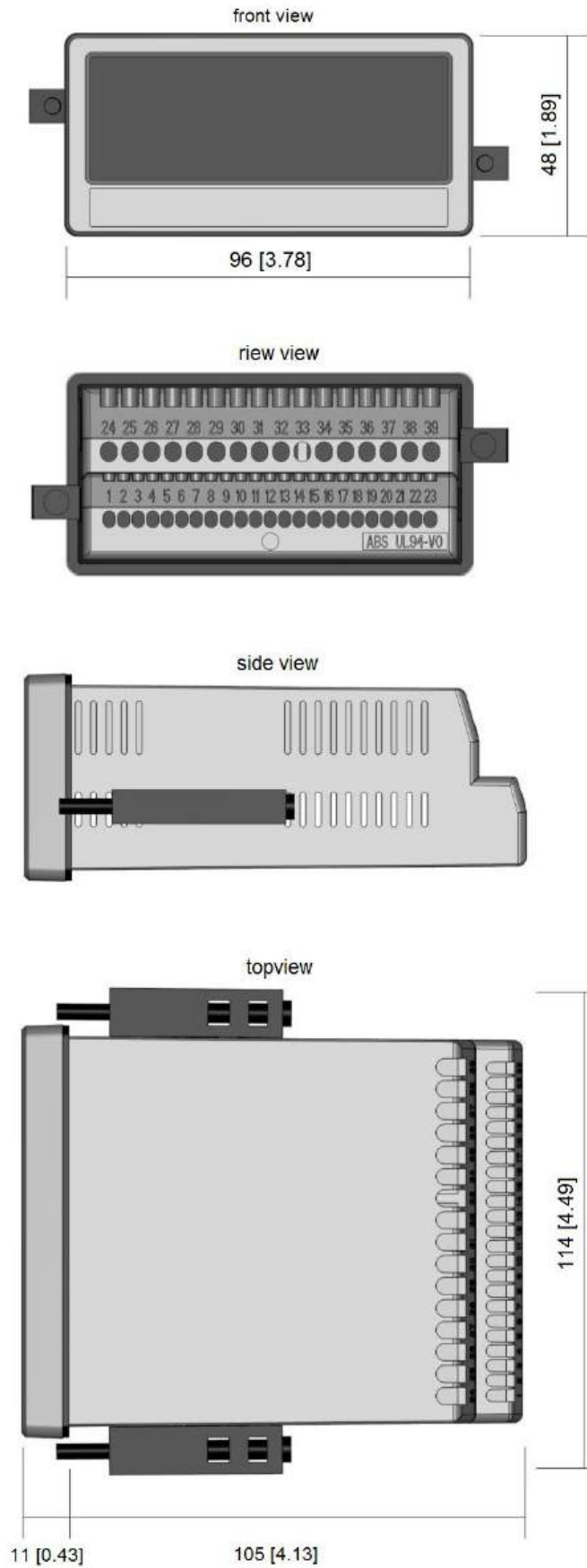

6.7. Technical specifications

Technical Specifications:		
Connections:	Connector type:	screw terminal, 1.5 mm ² / AWG 16
Power supply (DC):	Input voltage:	18 ... 30 VDC
	Protection circuit:	reverse polarity protection
	Consumption:	approx. 100 mA (unloaded)
	Fuse protection:	extern: T 0,5A
Power supply (AC): (Option AC)	Input voltage:	115...230 VAC ± 10%, 50...60 Hz)
	Power consumption:	approx. 3 VA (unloaded)
	Fuse protection:	extern: T 0,1 A
Encoder supply:	DC version:	approx. 1 V lower than the power supply voltage
	Output current:	max. 250 mA
	AC version (AC):	approx. 24 V (± 15%)
	Output current:	150 mA until 45°C resp. 113°F / 80 mA by more than 45°C resp. 113°F
Reference output:	Output voltage:	10 V
	Accuracy:	± 0.1 %
	Load:	max. 10 mA
Analog inputs:	Number of inputs:	2
	Configuration:	current or voltage operation
	Voltage input:	-10 ... +10 V (Ri ≈ 33 kOhm)
	Current input:	0 ... 20 mA / 4 ... 20 mA (Ri ≈ 100 Ohm)
	Resolution:	16 bit
	Accuracy:	± 0,1 %
Control inputs:	Number of inputs:	3
	Format:	HTL, PNP (Low 0 ... 3 V, High 9 ... 30 V)
	Frequency:	max. 1 kHz
	Reaction time	1 ms
	Load:	max. 2 mA at 24 VDC
Analog output: (Option AO/AR)	Configuration:	current or voltage operation
	Voltage output:	-10...+10 V (max. 2 mA)
	Current output:	0/4... 20 mA (burden: max. 270 Ohm)
	Resolution:	16 Bit
	Accuracy:	± 0,1 % 0°C ... +45°C / ± 0,1 % +32°F ... +113°F ± 0,15 % -20°C ... 0°C and +45°C ... +60°C / ± 0,15 % -4°F ... +32°F and +113°F ... +140°F
	Reaction time:	< 10 ms
Control outputs: (Option AO/AR/CO/CR)	Number of outputs:	4
	Format / level:	5 ... 30 V (depends on the Com+ voltage), PNP
	Output current:	max. 200 mA
	Reaction time:	< 1 ms
Relay outputs: (Option RL)	Number of outputs:	2
	Configuration:	potential free changeovers
	AC-Switching capacity:	max. 250 VAC / 3 A / 750 VA
	DC-Switching capacity:	max. 50 VDC / 1 A / 50 W
	Reaction time:	< 20 ms
Serial interface: (Option AO/AR/CO/CR)	Format (Option A0/CO):	RS232
	Format (Option AR/CR)	RS485
	Baud rate:	9600, 19200 or 38400 baud

Continuation "Technical specifications"

Display:	Type: Display range: Digit height (single + dual): Digit height (large sidplay): Colour: Operation:	Graphic LCD with backlight 8 digits plus sign (-99999999 ... 99999999) 13 mm (0.51 inch) 26 mm (1.02 inch) red/ green / yellow (switchable) resistive touchscreen
Housing:	Material: Mounting: Dimensions (w x h x d): Cut out (w x h): Protection class: Weight:	ABS, UL 94 V-0 panel 96 x 48 x 116 mm / 3.78 x 1.89 x 4.56 inch 91 x 43 mm / 3.58 x 1.69 inch IP65 (front), IP20 (rear) approx. 200 g
Ambient temperature:	Operation: Storage:	-20 °C ... +60 °C resp. -4 ... 140 °F Non condensing -25 °C ... +70 °C resp. -13 ... 158 °F
Ambient conditions:	Altitude: Humidity: Pollution Degree:	max. 2000 m (6560 ft) above sea level max. 80% relative humidity up to 30°C / 86°F 2
Conformity and standards:	EMC 2014/30/EU: LV 2014/35/EU: (Only for option AC and RL) RoHS (II) 2011/65/EU RoHS (III) 2015/863:	EN 61326-1: 2021 for industrial location EN 55011: 2016 + A1: 2017 + A11: 2020 + A2: 2021 Class A EN 61010-1: 2010 + A1:2019 + AC: 2019-04 EN IEC 61010-2-201: 2018 EN IEC 63000: 2018