

DIGITAL DISPLAY

for Industry Applications



Content:

Technical Data2
Technical Drawing3
Electrical Connection3
Plug-in Cards4
Programming & Software5
Order Code & Accessories6

Series PAXI

Key-Features:

- 6 digits, 14 mm high LEDs, annunciators
- 2 independent inputs
- Input signals TTL, NPN- and PNP-Sensors
- Measurement frequency max. 34 kHz
- 3 programmable user inputs
- Protection class IP65
- Working temperature 0 to 50 °C,
- Easy programming directly, or via PC
- Plug-in output-cards: analog, USB, Relay (thresholds), Transistor, RS232, Profibus
- Summation, min-/max value display
- 10 point scaling for non-linear processes

TECHNICAL DATA PAXI

Display	6 digits, 14 mm high, red LEDs
Panel cut-out	92 mm x 45 mm
Annunciators	A, B, C (counter), SP1, SP2, SP3, SP4 (the respective output is active)
Programmable user inputs	3, logic state: jumper selectable for sink/source logic PNP: active $V_{in} > 2.4$ VDC, inactive $V_{in} < 0.9$ VDC, NPN: active $V_{in} < 0.9$ VDC, inactive $V_{in} > 2.4$ VDC
Input signal	incremental sensors with TTL signal, NPN and PNP sensors (settings by DIP switches)
Output signal (via plug-in cards)	Relay output, transistor output, analog output
Serial Interfaces (via plug-in cards)	USB port (programmable), RS485, RS232, Profibus
Prescaler Output	NPN Open Collector: $I_{SNK} = 100$ mA, max $V_{OH} = 30$ VDC
Supply voltage	PAXI003B: 11...36 VDC/24 VCA, PAXI002B: 85...250 VAC
Sensor supply	12 VDC, $\pm 10\%$, regulated, max. 100 mA
Measurement rate	max. 34 kHz
Tachometer	Accuracy $\pm 0.01\%$
Scaling	All counters and the tachometer can be scaled independently of each other
Protection class	IP65 (face only)
Humidity	max. 85%, no condensation
Working temperature	0...+50°C, unit supplied with 3 plug-in cards: 0...+45°C
Housing	Plastics, 97 mm x 50 mm x 104 mm
Weight	300 g, unit without plug-in cards
Electromagnetic compatibility	conform to CE , EN 50081-2, EN50082-2
Delivery	Display, mounting material, sealing, manual

TECHNICAL DRAWING PAXI

PAXI

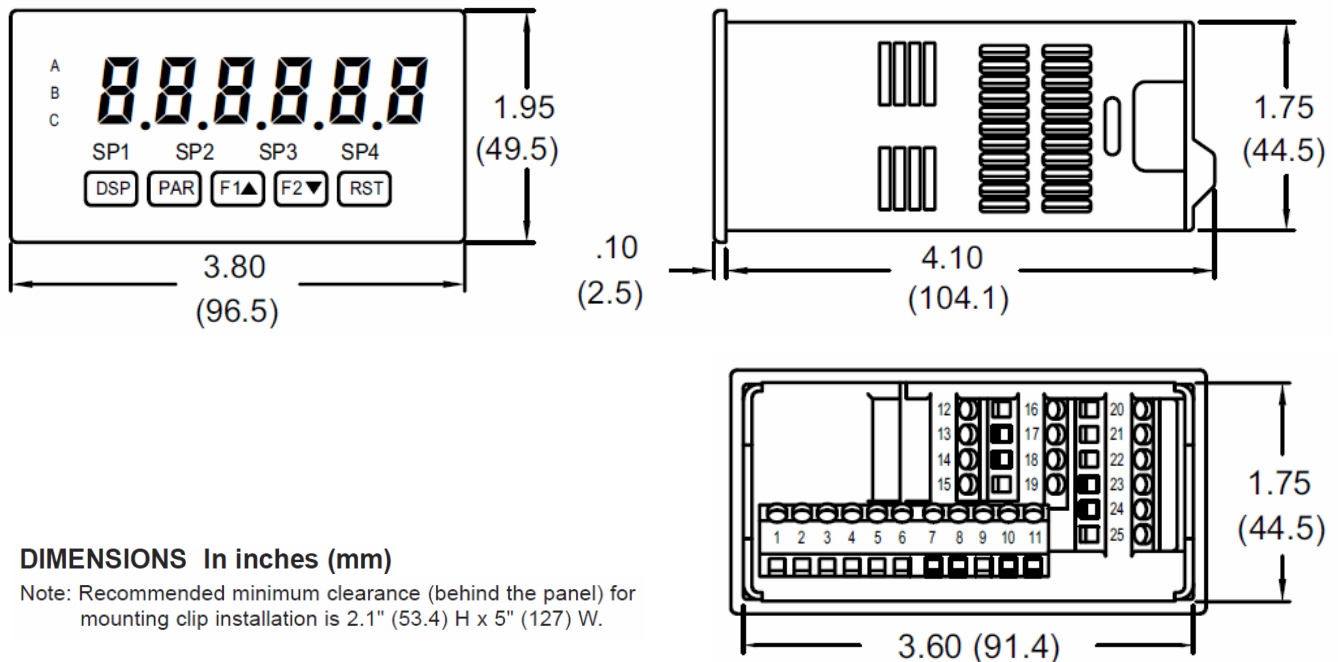

ELECTRICAL CONNECTION PAXI

Assignment PAXI

1	AC +	Power supply PAXI002B: 85 to 250 VAC PAXI003B: 11 to 36 VDC
2	AC -	Power supply PAXI002B: 85 to 250 VAC PAXI003B: 11 to 36 VDC
3	+EXC	Sensor supply 12 VDC/100 mA
4	COMM.	GND signal input
5	CNT A	Counter A
6	CNT B	Counter B
7	USER 1	User input 1
8	USER 2	User input 2
9	USER 3	User input 3
10	COMM.	GND User input
11	PS OUT	Prescaler output, NPN,O.C.

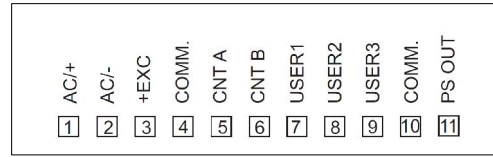

Caution: Sensor input common is NOT isolated from user input common. In order to preserve the safety of the meter application, the sensor input common must be suitably isolated from hazardous live earth referenced voltages; or input common must be at protective earth ground potential. If not, hazardous live voltage may be present at the User Inputs and User Input Common terminals. Appropriate considerations must then be given to the potential of the user input common with respect to earth common; and the common of the isolated plug-in cards with respect to input common.

Setting the Jumpers

To access the jumper and switches, remove the meter base from the meter case by firmly squeezing and pulling back on the side rear finger tabs. This should lower the latch below the case slot (which is located just in front of the finger tabs). It is recommended to release the latch on one side, then start the other side latch.

Setting the jumper

The meter has one jumper for user input logic. When using the user inputs this jumper must be set before applying power. The user input jumper determines signal logic for the user inputs, when they are used with user functions or for input signal direction. All user inputs are set by this jumper.

Setting the Input DIP Switches

The meter has six DIP switches for Input A and Input B terminal set-up that must be set before applying power. NOTE: The PAXR only uses switches 1-3.

SWITCHES 1 and 4

LOGIC: Input trigger levels $V_{IL} = 1.5 \text{ V max.}; V_{IH} = 3.75 \text{ V min.}$

MAG: 200 mV peak input (must also have SRC on). Not recommended with counting applications.

SWITCHES 2 and 5

SRC.: Adds internal 3.9 K Ω pull-down resistor, 7.3 mA max. @ 28 VDC, $V_{MAX} = 30 \text{ VDC.}$

SNK.: Adds internal 7.8 K Ω pull-up resistor to +12 VDC, $I_{MAX} = 1.9 \text{ mA.}$

SWITCHES 3 and 6

HI Frequency: Removes damping capacitor and allows max. frequency.

LO Frequency: Adds a damping capacitor for switch contact bounce. Also limits input frequency to 50 Hz and input pulse widths to 10 msec.

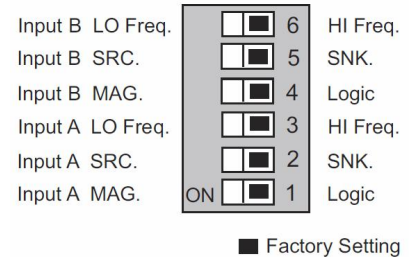

HOUSING

Aluminium housing GEH01P65

- black powder coating
- internal grounding terminal.
- protection class: IP65
- dimensions: (W x H x D) 168 mm x 83 mm x 220 mm
- delivery: housing, mounting material
- without cable passages (must be drilled individually)



Table housing TG9648

- The housing is suited for all displays with front dimensions 96 x 48 mm
- self assembly
- dimensions: (W x H x D) 114 mm x 62 mm x 176 mm
- delivery: housing, mounting material

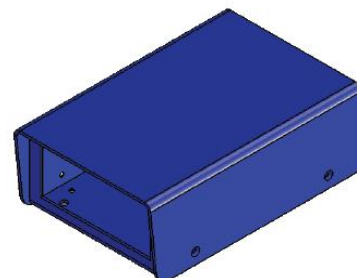

PLUG-IN CARDS

The display can be fitted with up to three optional plug-in cards. The details for each plug-in card can be reviewed in the specification section below. Only one card from each function type can be installed at one time. The plug-in cards can be installed initially or at a later date.

Analog Output Card (retransmitted linear DC output): PAXCDL10

- Types: 0 to 20 mA, 4 to 20 mA, or 0 to 10 VDC.
- Isolation to sensor + user input commons: 500 Vrms for 1 min., working range 50V, not isolated from all other commons.
- Accuracy: 0.17 % of FS (10 to 28 degree Celsius), 0.4% (0 to 50 degree Celsius)
- Resolution 1/3500
- Compliance: 10 VDC, 10 kOhm load min., 20 mA, 500 Ohm max. load

Setpoint Alarm Output Cards

Quad sourcing open collector card: PAXCDS40

- 4 isolated sourcing x PNP transistors
- Internal supply: 24 VDC +/- 10%, 30 mA max. total
- Isolation to sensor + user input commons: 500 Vrms for 1 min., working range 50V, not isolated from all other commons.
- External supply: 30 VDC max., 100 mA max. each output

Quad sinking open collector card: PAXCDS30

- 4 isolated sinking x NPN transistors
- Isolation to sensor + user input commons: 500 Vrms for 1 min., working range 50V, not isolated from all other commons.
- Rating: 100mA max. at $V_{sat}=0,7 V_{max}$, $V_{max}: 30V$

Dual relay card: PAXCDS10

- 2 x FORM-C relays, 5 A at 120/240 VAC or 28 VDC (Ohm load) at 120 VAC (80 VA inductive load)
- Life expectancy: 100.000 cycles min. at full load.

Quad relay card: PAXCDS20

- 4 x FORM-A relays, 3 A at 250 VAC or 30 VDC (Ohm load) at 120 VAC (80 VA inductive load)
- Life expectancy: 100.000 cycles min. at full load.

Interface Cards:

- RS232, programmable, version with Sub-D connector: PAXCDC2C or with terminal: PAXCDC20
- Multipoint RS485, programmable: PAXCDC10
- DeviceNet, programmable: PAXCDC30
- Profibus-DP: PAXCDC50

Isolation 500V, not isolated from all other commons.

USB CARD: PAXUSB00

- only suited for slow measurement (for high dynamic measurement please use the RS232 card).
- USB virtual COM Port
- Connection: type mini B

Installing plug-in cards:

- With the display removed from the case, locate the plug-in card connector for the card type to be installed. The types are keyed by position with different main circuit board connector locations. When installing the card, hold the display by the rear terminals and not by the front display board. If installing the Quad sourcing card, set the jumper for internal or external supply operation before continuing.
- Install the card by aligning the card terminals with the slot bay in the rear cover.
- Slide the display back into the case. Be sure the rear cover latches fully into the case.
- Apply the plug-in card label to the bottom side of the display in the designated area.

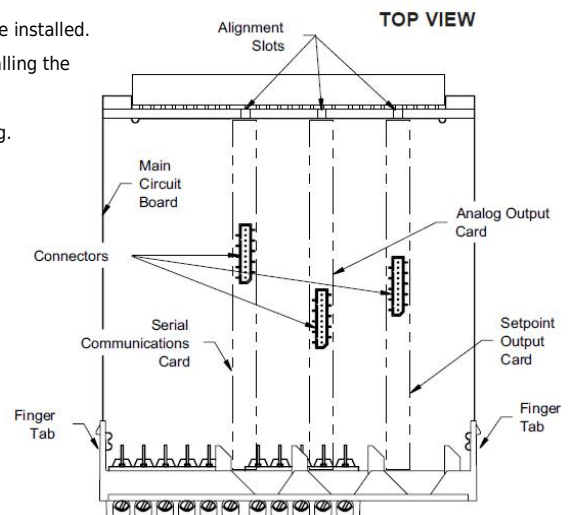
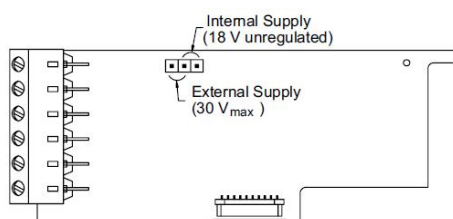

PROGRAMMING

Directly by the displays keys

The meter normally operates in the Display Mode. No parameters can be programmed in this mode. The Programming Mode is entered by pressing the **PAR** key. If it is not accessible then it is locked by either a security code, or a hardware lock.

Two types of programming modes are available. Quick Programming Mode permits only certain parameters to be viewed and/or modified. All meter functions continue to operate except the front panel keys change to Programming Mode Operations. Quick Programming Mode is configured in Module 3. Full Programming Mode permits all parameters to be viewed and modified. In this mode, incoming counts may not be recognized correctly, the front panel keys change to Programming Mode Operations and certain user input functions are disabled. Throughout this document, Programming Mode (without Quick in front) always refers to "Full" Programming.

By Software

Additionally, the meters have a feature that allows a remote computer to directly control the outputs of the meter. With an RS232 or RS485 card installed, it is possible to configure the meter using a Windows® based program. The configuration data can be saved to a file for later recall.

You will find a detailed description of the programming in the manual that is included in the delivery.

PACKAGE FOR THE CONNECTION PAX TO PC

SFCRUSB1

Package for the connection of PAX displays to the USB interface of a PC:

- includes USB plug-in card PAXUSB00
- USB interface cable
- Software Crimson 2: The Crimson software is a Windows based program that allows configuration of the PAX display from a PC. Crimson offers standard drop-down menu commands, that make it easy to program the meter. The meter's program can then be saved in a PC file for future use. A PAX serial plug-in card or PAX USB programming card is required to program the meter using the software.

Please keep in mind that the USB interface is limited in its speed of data transfer. In fast applications data might get lost. In such cases the faster RS232 interface should be chosen.

Note: the USB interface is restricted in its ability to communicate with the Software ProLOG.

ProLOG

Analysis- and Visualisation software for Windows-based Systems

Visualisation of the measurement data on a Windows PC, with the option of storing the data in a CSV file.

ORDER CODE

PAXI002B Voltage supply: 85 to 250 VAC

PAXI003B Voltage supply: 11 to 36 VDC/24 VAC

ACCESSORIES

Plug-in cards

PAXCDC10 Serial communication card RS485

PAXCDC20 Serial communication card RS232, terminal

PAXUSB00 Interface card USB

PAXCDC50 Interface card PROFIBUS-DP

PAXCDL10 Analog output card

PAXCDS10 Dual relay, Form-C, normally open & closed

PAXCDS20 Quad relay, Form-A, normally open only

PAXCDS30 Quad sinking NPN open collector

PAXCDS40 Quad sourcing PNP open collector

PAXCDC2C Serial communication card RS232, 9 pole SUB-D connector

Miscellaneous

PAXLBK10 Units label kit

Einstellung Pre-adjustment according to customer demands

Software

Crimson 2 on request

ProLOG on request

Packages

SFCRUSB1 includes USB plug-in card PAXUSB00

USB interface cable

Software Crimson 2

Housings

GEH0IP65 Aluminium housing, IP65

TG9648 Table housing

Subject to change without prior notice.

WayCon Positionsmesstechnik GmbH

email: info@waycon.de

internet: www.waycon.de

Head Office

Mehlbeerenstr. 4

82024 Taufkirchen

Tel. +49 (0)89 67 97 13-0

Fax +49 (0)89 67 97 13-250

Office Köln

Auf der Pehle 1

50321 Brühl

Tel. +49 (0)2232 56 79 44

Fax +49 (0)2232 56 79 45