

MANUAL

Links to further documents for LDI:

[Data sheet LDI](#)

[Manual standard LDI](#)

[Manual digital interfaces LDI](#)

[Catalogue](#)



LKG-LDI

Air cooling jacket **LKG-LDI** and **LKG-LDI-ENET**
for Laser Displacement Sensor LDI

TABLE OF CONTENT

General informaion	3
Specification	3
Assembly air cooling jacket LKG-LDI.....	3
Assembly air cooling jacket LKG-LDI-ENET.....	5
Base alignment.....	6
Mounting air line	7
LED Status.....	7
Air cooling jacket structure	7
Air cooling	8
Technical drawing LKG-LDI	8
Technical drawing LKG-LDI-ENET.....	9

GENERAL INFORMATION

LKG-LDI:

This air cooling jacket can be used with all LDI Series Laser Displacements that are equipped with standard interfaces.

LKG-LDI-ENET:

This air cooling jacket can be used with all LDI Series Laser Displacements that are equipped with the interface extensions ProfiNet, EtherNet/IP and EtherCAT.

SPECIFICATION

Outer tube diameter	8 mm
Air nipple size	PT 1/8"
Cable gland	M16 standard interface M32 Industrial Ethernet Interface
Mounting	Mounting slots for M5 / M4 screws
Size	width: 85 mm x length: 290 mm x height: 151 mm
Weight approx.	1.405 kg
Material	Housing body: Aluminum Hard anodizing
Not included	The LDI Laser Displacement, Air-cleaner, Air-dryer, Air-filter, Pressure reduction, air regulator, and cables are not included

ASSEMBLY AIR COOLING JACKET LKG-LDI

First insert the cables into the cable gland of the jacket. Then insert them into that of the laser sensor before you assemble the laser sensor to the air cooling jacket (cable diameter: 5 up to 8 mm)

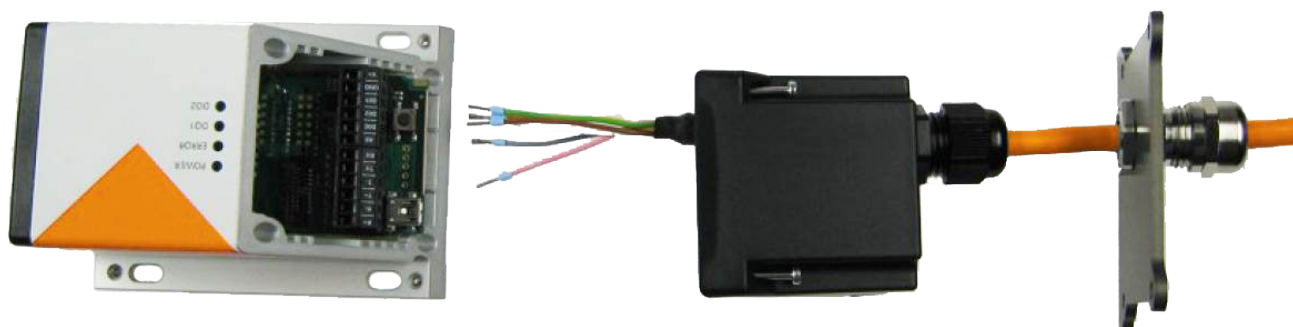

The laser sensor's cable gland can be used in a narrow space of the jacket as the inserted cable gland of the laser sensor and the jacket is designed to be aligned.



ASSEMBLY AIR COOLING JACKET LKG-LDI

Then close the sensor's rear cover after wiring to the laser sensors's terminal board. Tighten the black cable gland.

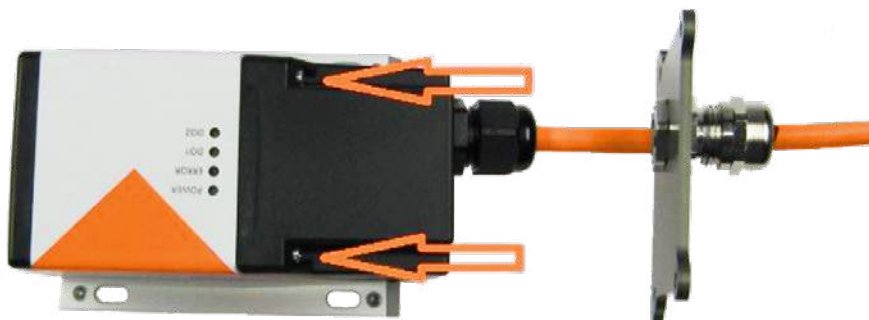

Remove the four hexagonal socket set screws. You need these tapped holes to mount the sensor into the jacket.

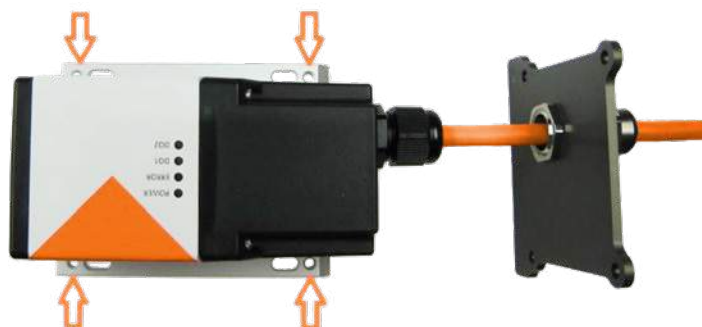

Slide the sensor into the air jacket.



Set the four screws and attach the sensor to the housing. The screws are automatically provided.

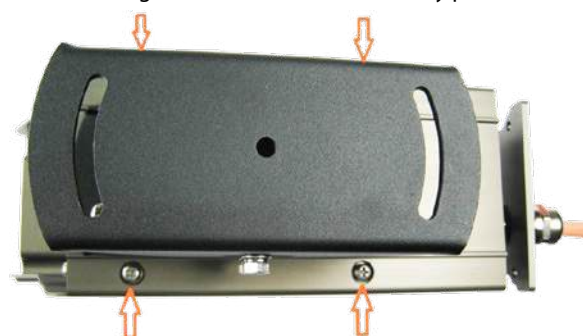

ASSEMBLY AIR COOLING JACKET LKG-LDI

When you close the rear cover of the air cooling jacket, installation is easier without bending the cable inside the enclosure.

Set the four screws and attach the rear cover.

Finally, tighten the metallic cable gland.



ASSEMBLY AIR COOLING JACKET LKG-LDI-ENET

First cut a hole in the rubber seal which you find in the cable gland.



Insert the cables into the cable gland, then insert them into the rubber seal.



Insert the cables into the cable gland of the rear cover. Then push the rubber seal into the cable gland.

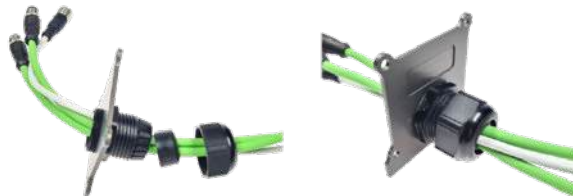

Remove the four hexagonal socket set screws. You may need these tapped holes to mount the sensor into the air cooling jacket.



Connect the cables for Power and Ethernet interface to the rear cover.



ASSEMBLY AIR COOLING JACKET LKG-LDI-ENET

Slide the wired sensor into the air cooling jacket.



Fasten the cable gland after adjusting an appropriate cable length to be inserted.

Close the rear cover of the jacket and fasten the four screws. (M4 x 50)



To fix the device in case you have 2 options.

Option 1: Set the four screws and attach the sensor to the housing.

Option 2: Fix the sensor after tightening the screws on both sides of the jacket.



BASE ALIGNMENT

The tilting can be adjusted with the four screws on the two sides of the air cooling jacket. We recommend manually supporting the housing for alignment to prevent damaging the product because the housing's center of gravity is lunched forward.



The rotation can be adjusted with the main fixing screws.



MOUNTING AIR LINE

Connect the 8 mm tube into the quick coupling.



Remove the tube from quick coupling.



LED STATUS

The user can see the sensor's operating status through the clear glasses on the housing top without pulling the laser sensor out. This makes it convenient to do maintenance or monitoring device on site.



AIR COOLING JACKET STRUCTURE

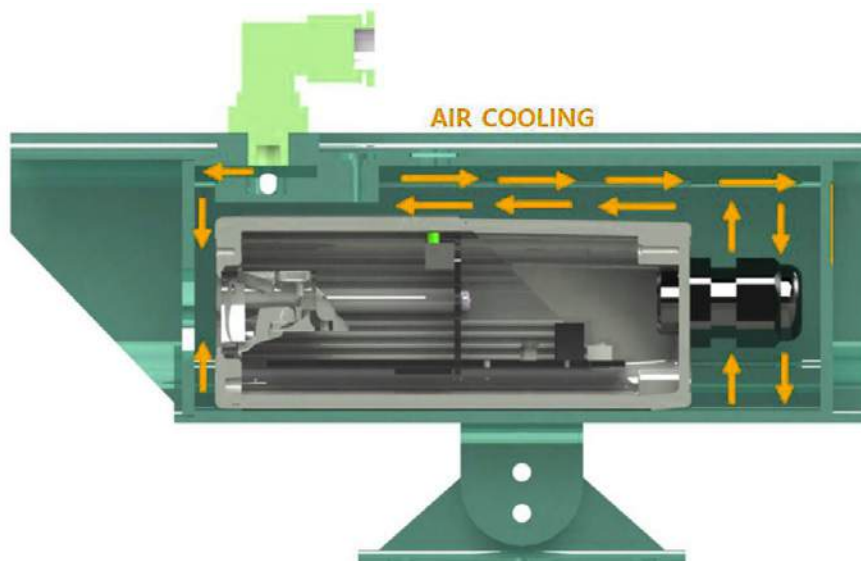
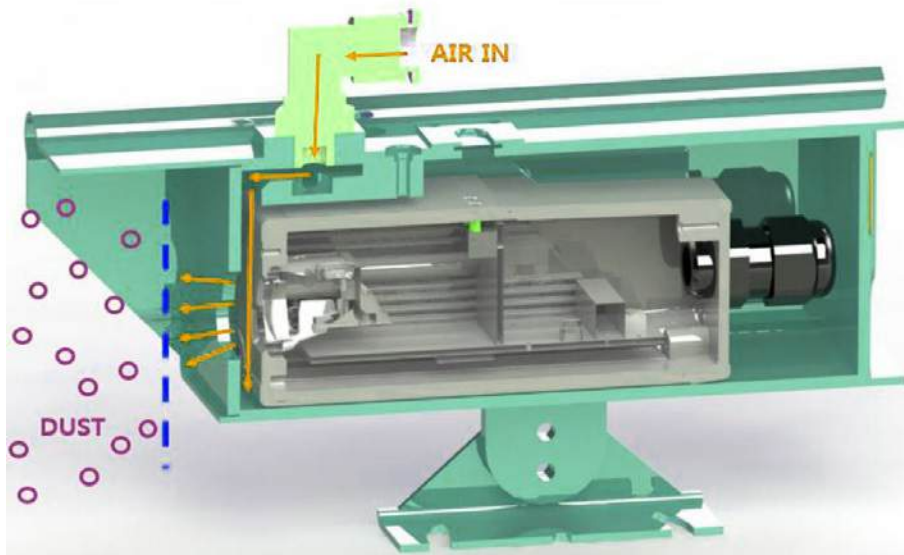

AIR COOLING

Generally, the provided air must be clean, oil- and moisture free. Please use all the necessary equipment. The air guide block has a jaw trough which oil and moisture are discharged through drainage channels. Only fresh air is left inside the housing, thus it performs both cooling and air purging functions.

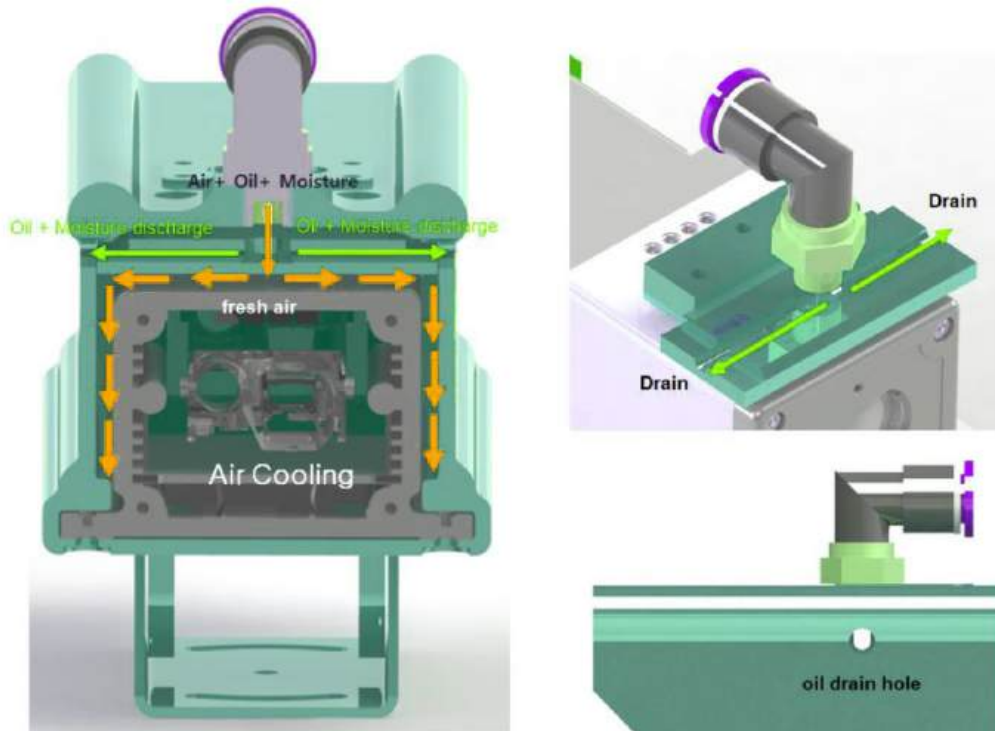

TECHNICAL DRAWING LKG-LDI

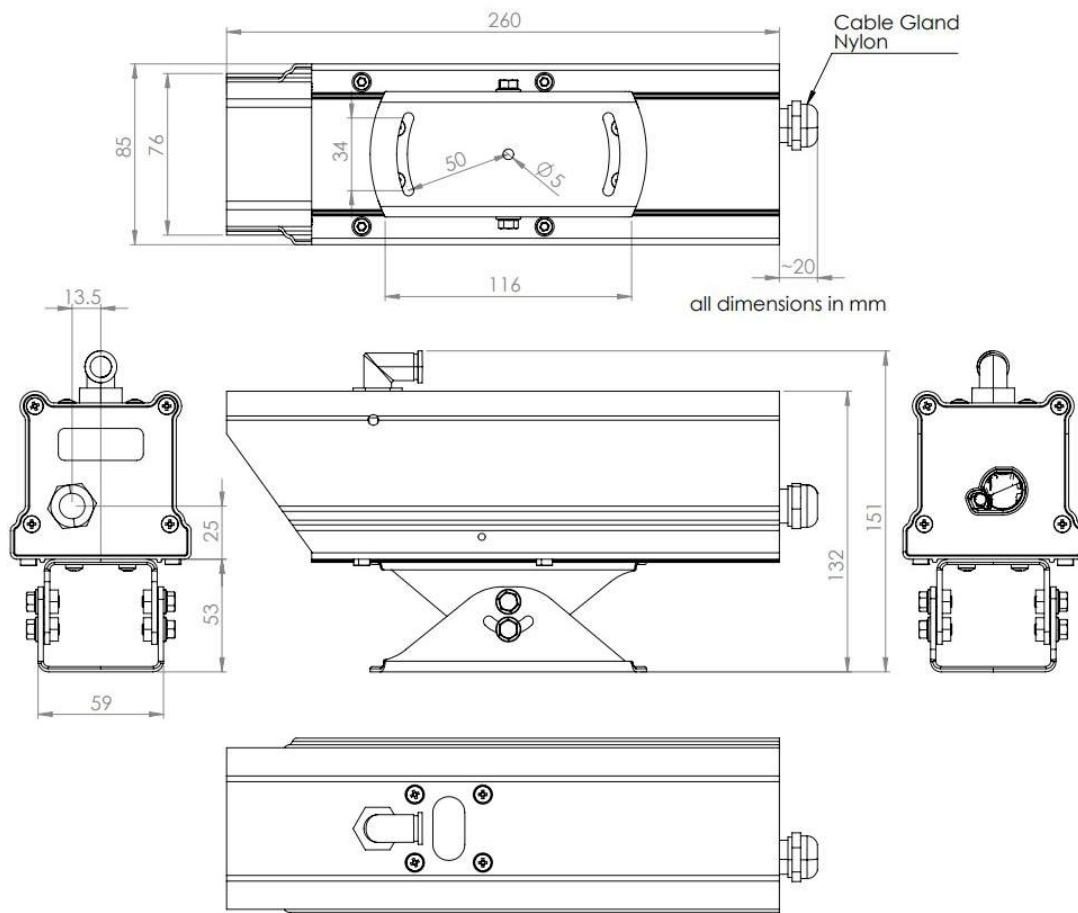

TECHNICAL DRAWING LKG-LDI-ENET

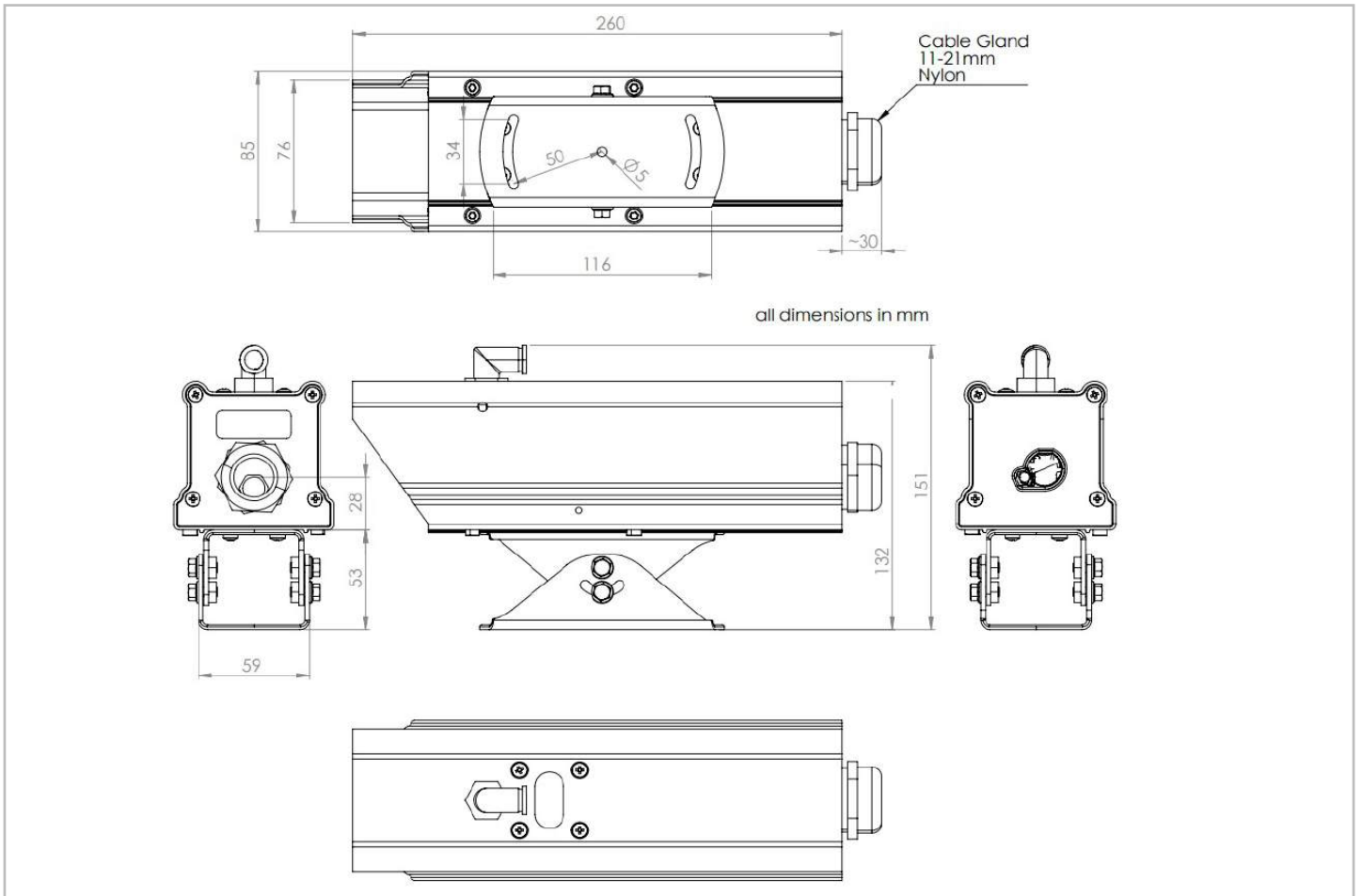

Subject to change without prior notice.

WayCon Positionsmesstechnik GmbH
Email: info@waycon.de
Internet: www.waycon.biz

WayCon
Positionsmesstechnik

Headquarters Munich
Siemensstr. 5
85521 Ottobrunn
Tel. +49 (0)89 67 97 13-0

Office Cologne
Auf der Pehle 1
50321 Brühl
Tel. +49 (0)89 67 97 13-100