



## NOTES

All the data reported in this brochure and the data sheet, like linearity, lifetime, temperature coefficient are valid for a sensor utilization as a ratiometric device with a max current across the cursor  $I_c \leq 0.1$  mA.

Do NOT use the sensor as variable resistance!

When calibrating the transducer, be careful to set the stroke so that the output does not drop below 1% or rise above 99% of the voltage level.

## MAINTENANCE

The sensors are maintenance free. However we recommend to lubricate the moving parts of the LSW every 6 months.

# INSTALLATION GUIDE

## Linear Potentiometer Series LSW

For further information please see the data sheet at [www.waycon.biz/products/linear-potentiometers/](http://www.waycon.biz/products/linear-potentiometers/)

## FIRST STEPS

WayCon Positionsmesstechnik GmbH would like to thank you for the trust you have placed in us and our products. This manual will make you familiar with the installation and operation of our linear potentiometers. Please read this manual carefully before initial operation!

Unpacking and checking:

Carefully lift the linear transducer out of the box by grabbing the housing. After unpacking the device, check it for any visible damage as a result of rough handling during the shipment. Check the delivery for completeness.

If necessary consult the transportation company, or contact WayCon directly for further assistance.

## MOUNTING THE SENSOR

### Groove mounting

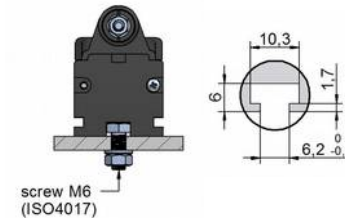

### Mounting with brackets (included in delivery)

PKIT059: 2 brackets, screws (100 - 900 mm)

PKIT061: 3 brackets, screws (1000 - 2000 mm)

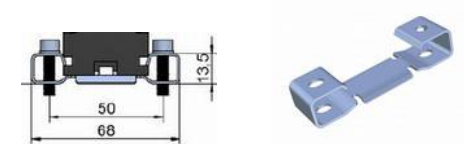

## ELECTRICAL CONNECTION

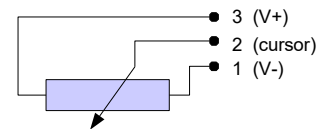

Sensor is to be used as voltage divider, using a maximum cursor current of  $I_c \leq 0.1$   $\mu$ A (do NOT use the sensor as variable resistance!). Please pay attention to the notes on the last page.

output LSW-M

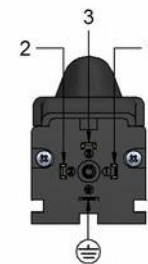

output LSW-B

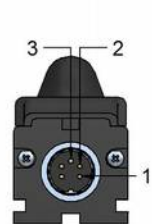

# INSTALLATION GUIDE

## Linear potentiometer Series LSW

For further information please see the data sheet at [www.waycon.biz/products/linear-potentiometers/](http://www.waycon.biz/products/linear-potentiometers/)

### TECHNICAL DRAWING

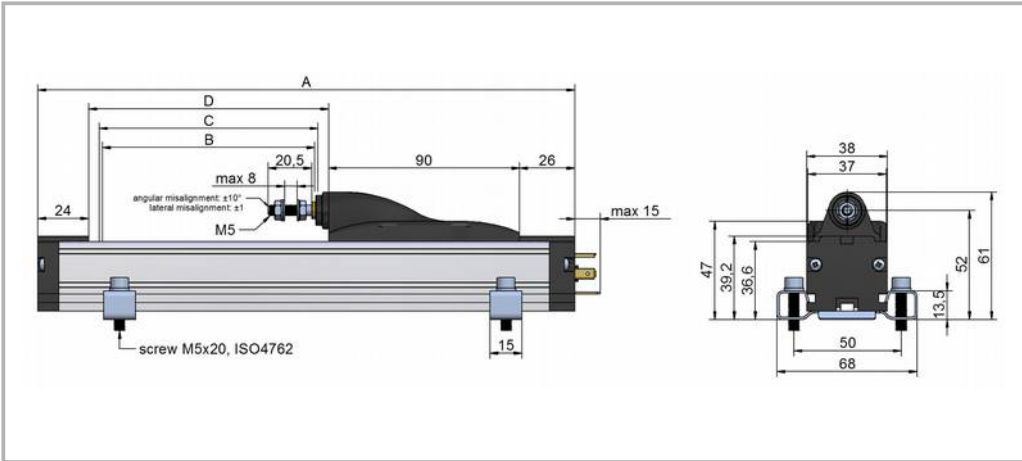

### TECHNICAL DATA

Useful electrical stroke B: corresponds to the sensors measurement range

Theoretical electrical stroke C: actual length of the conductive path, that has to be longer than B, in order to get a valid electrical signal at the start and end point of the measurement range.

When calibrating the transducer, be careful to set the stroke so that the output does not drop below 1% or rise above 99% of the voltage level.

Measurement range	[mm]	100	130	150	200	225	300	400	450	500	600	750	900	1000	1250	1500	1750	2000
Useful electrical stroke (B) +3/-0	[mm]	100	130	150	200	225	300	400	450	500	600	750	900	1000	1250	1500	1750	2000
Theoretical electrical stroke (C) ±1	[mm]	103	133	153	204	229	305	406	458	509	611	763	915	1017	1271	1521	1771	2021
Resistance	[kOhm]	5			10			20										
Mechanical stroke (D)	[mm]	113	143	163	214	239	315	416	468	519	621	773	925	1027	1281	1531	1781	2031
Housing length (A)	[mm]	253	283	303	354	379	455	556	608	659	761	913	1065	1167	1421	1671	1921	2171



### ACCESSORIES

#### LSW-M

CON006:  
mating connector,  
IP40, 4 pole, PG9 cable gland

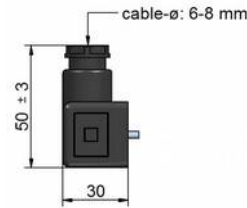

#### LSW-M

CON006-M12:  
mating connector,  
adapter to M12

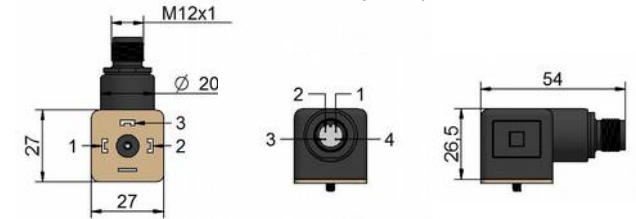

Signal	Pin	Cable colour K4P...
V-	1	brown
cursor	2	white
V+	4	black

#### LSW-B

CON011:  
mating connector, IP40,  
5 pole, cable diameter 4...6 mm



#### Spare Parts

PKIT059	2 brackets, screw s
	for ranges: 100 – 900 mm
PKIT061	3 brackets, screw s
	for ranges: 1000 – 2000 mm

#### Cable with connector M12, 4 poles, shielded, IP67

K4P2M-S-M12	2 m, connector straight
K4P5M-S-M12	5 m, connector straight
K4P10M-S-M12	10 m, connector straight
K4P2M-SW-M12	2 m, connector angular
K4P5M-SW-M12	5 m, connector angular
K4P10M-SW-M12	10 m, connector angular

#### PMX-24 Signal Conditioner

- Converts potentiometer signals into analog output signals: 4...20 mA, 0...10 V, 0...5 V, ±10 V, ±5 V
- Input: potentiometer 1...20 kΩ
- Configurable output
- DIN-rail-mounting with face-side connector
- For further information please check the PMX-24 data sheet, or contact WayCon

