



NOTES

All the data reported in this brochure and the data sheet, like linearity, lifetime, temperature coefficient are valid for a sensor utilization as a ratiometric device with a max current across the cursor $I_c \leq 0.1 \text{ mA}$.

Do NOT use the linear transducer as variable resistance!

When calibrating the transducer, be careful to set the stroke so that the output does not drop below 1% or rise above 99% of the voltage level.

MAINTENANCE

The sensors are maintenance free. It is not necessary to lubricate the moving parts.

INSTALLATION GUIDE

Linear Potentiometer Series LZW2

For further information please see the data sheet at www.waycon.biz/products/linear-potentiometers/

FIRST STEPS

WayCon Positionsmesstechnik GmbH would like to thank you for the trust you have placed in us and our products. This manual will make you familiar with the installation and operation of our linear potentiometers. Please read this manual carefully before initial operation!

Unpacking and checking:

Carefully lift the device out of the box by grabbing the housing. After unpacking the device, check it for any visible damage as a result of rough handling during the shipment. Check the delivery for completeness.

If necessary consult the transportation company, or contact WayCon directly for further assistance.

ELECTRICAL CONNECTION

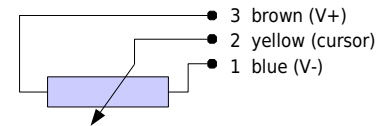

Sensor is to be used as voltage divider, using a maximum cursor current of $I_c \leq 0.1 \mu\text{A}$ (do NOT use the sensor as variable resistance!). Please pay attention to the notes on the last page.

ACCESSORIES

Spare parts

- STA075 bracket for LZW2-S
- SND004 rod end bearing with M4 external thread, housing side for LZW2-A
- SND005 rod end bearing with M4 internal thread, rod side for LZW2-A

PMX-24 Signal Conditioner

- Converts potentiometer signals into analog output signals: 4...20 mA, 0...10 V, 0...5 V, $\pm 10 \text{ V}$, $\pm 5 \text{ V}$
- Input: potentiometer 1...20 k Ω
- Configurable output
- DIN-rail-mounting with face-side connector
- For further information please check the PMX-24 data sheet, or contact WayCon



INSTALLATION GUIDE

Linear potentiometer Series LZW2

For further information please see the data sheet at www.waycon.biz/products/linear-potentiometers/

TECHNICAL DRAWING

LZW2-S: installation with brackets

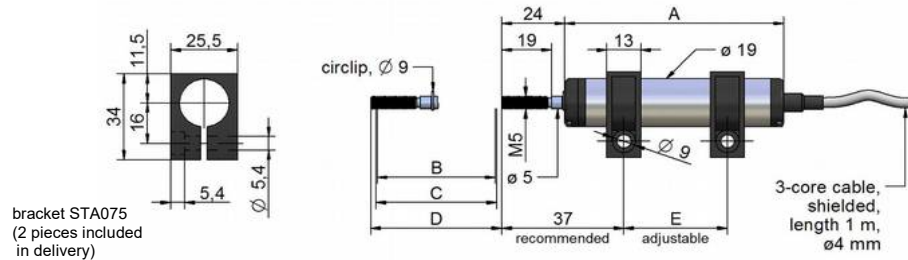

LZW2-A: installation with rod end bearings

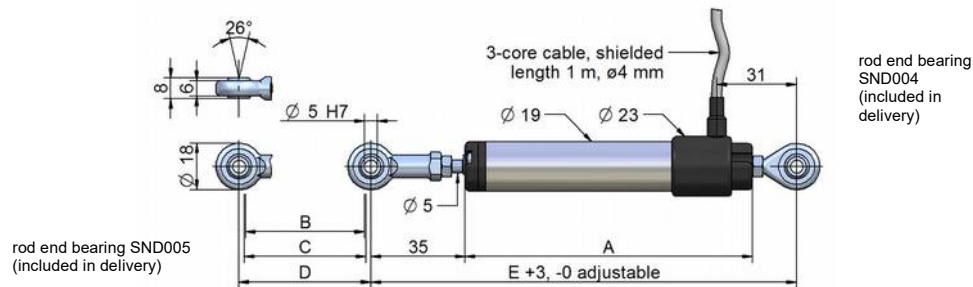

LZW2-F: installation with flange

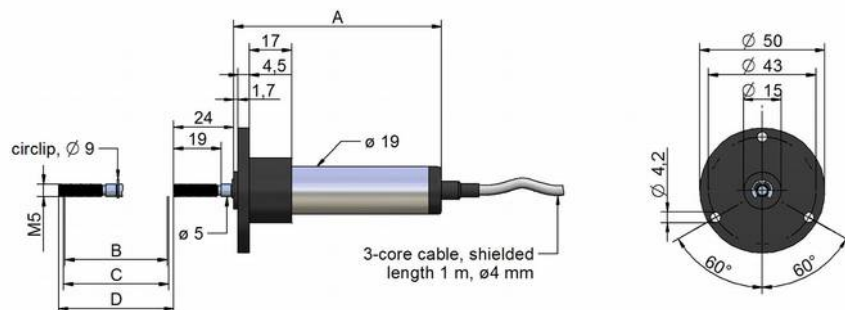

TECHNICAL DATA

Useful electrical stroke B: corresponds to the sensors measurement range

Theoretical electrical stroke C: actual length of the conductive path, that has to be longer than B, in order to get a valid electrical signal at the start and end point of the measurement range.

When calibrating the transducer, be careful to set the stroke so that the output does not drop below 1% or rise above 99% of the voltage level.

Measurement range	[mm]	25	50	75	100	125	150	175	200	250	300	
Electrical stroke (B) +1/-0	[mm]	25	50	75	100	125	150	175	200	250	300	
Theoretical electrical Stroke (C) ±1	[mm]	B +1										
Resistance	[kOhm]	1	2	3	4	5	6	7	8	10	12	
Linearity	[±%]	0.2	0.1	0.1	0.1	0.05	0.05	0.05	0.05	0.05	0.05	
Max. dissipation at 40°C (0 W at 120°C)	[W]	0.8	1.6	2.8	3							
Maximum power supply	[V]	20	40	60								
Mechanical stroke (D)	[mm]	B +5										
Case length (A) LZW1-S	[mm]	83.5	108.5	133.5	158.5	183.5	208.5	233.5	258.5	308.5	358.5	
Case length (A) LZW1-A	[mm]	110	135	160	185	210	235	260	285	335	385	
Case length (A) LZW1-F	[mm]	83.5	108.5	133.5	158.5	183.5	208.5	233.5	258.5	308.5	358.5	
Recommended distance brackets (E)	[mm]	47	72	97	122	147	172	197	222	272	322	
Minimum distance rod end bearings (E)	[mm]	163	188	213	238	263	288	313	338	388	438	
Weight LZW1-S	[g]	90	105	130	160	175	190	205	215	245	275	
Weight LZW1-A	[g]	110	125	150	180	195	210	225	235	260	285	
Weight LZW1-F	[g]	100	115	140	170	185	200	215	225	255	280	