



TROUBLESHOOTING

Error	What to do
No function, or current output: constantly 0.75 mA	If connected correctly the green LED is on. If not, check the connection. Disconnect the potentiometer: Error LED must be flashing. Control voltage output between PIN 11 and 12. Control current output between PIN 11 and 13. Control 10 V reference voltage for potentiometer between PIN 5 and 7. Control potentiometer signal between PIN 6 and 7.
Reduced measurement range + drift in current output	Voltage output PIN 12 is used for current measurement. Use Pin 13. Also check the DIP-Switch settings on the circuit board.

The signal converter is working correctly if the 10 V reference voltage is delivered. This can easily be checked when no potentiometer is connected. In this case the potentiometer may be corrupted. If the PMX-24 does not deliver the 10 V reference voltage it is damaged. Please contact the WayCon repair service at sales@wacon.de.

INSTALLATION GUIDE

Signal Conditioner PMX-24

For further information please see the data sheet at www.wacon.biz/products/signal-conditioners/

FIRST STEPS

WayCon Positionsmesstechnik GmbH would like to thank you for the trust you have placed in us and our products. This manual will make you familiar with the installation and operation of our draw wire sensors. Please read this manual carefully before initial operation!

Unpacking and checking:

Carefully lift the device out of the box by grabbing the housing. After unpacking the device, check it for any visible damage as a result of rough handling during the shipment. Check the delivery for completeness. If necessary consult the transportation company, or contact WayCon directly.

MOUNTING

The PMX-24 is designed to be mounted on a 35 mm DIN rail bar, in a vertical position. Always make sure that there is sufficient ventilation. We recommend to install the signal converter in the lower part of the control cabinet.

TECHNICAL DATA

Output	4...20 mA, 0...10 V, 0...5 V, ± 10 V, ± 5 V, adjustable via DIP switch, electrically isolated, 4 wire technology
Input	Potentiometer with 1...20 k Ω
Supply	9...36 VDC
Max. supply current	30 mA, max. 44 mA (with current output in use)
Max. shunt current output	< 300 Ω
Dynamics	300 Hz (-3 dB) active 6-pole Bessel filter
Noise	<1 mV _{rms}
Reverse voltage protection	yes, infinite
Short-circuit proof	yes, permanently short-circuit-proof
Working temperature	-40...85 °C
Temperature coefficient < 15°C	0.00032 %/K
Temperature coefficient > 15°C	0.00005 %/K
Power-on drift	0.0025% of FS without warming up
Connection technology	4 wire technology
Protection class	IP30 (EN60529)

INSTALLATION GUIDE

Signal Conditioner PMX-24

For further information please see the data sheet at www.waycon.biz/products/signal-conditioners/

ELECTRICAL CONNECTION

The housing of the conditioner can be opened by sliding off the cover at the indicated locations. Tools are not required.

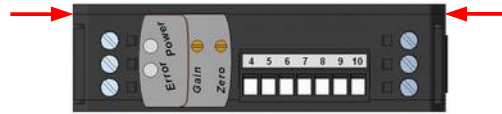

After removing the protective foil, the DIP switches on the top of the board can be set to the desired output signal.

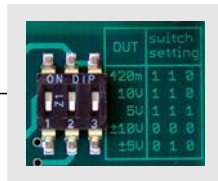

OUT	Switch Setting		
420 mA	1	1	0
10 V	1	1	0
5 V	1	1	1
±10 V	0	0	0
±5 V	0	1	0

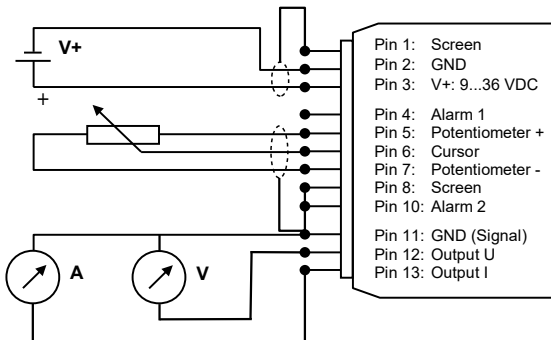

Please use shielded cables for the connection of the device. Strong electromagnetic sources, like power lines close to the converter or its lines should be avoided.

Note:
 GND signal and GND can be connected if 3 wire technology is used.
 Pin 1 and Pin 8 are internally connected.

!! The PMX is a live power source !!

The open circuit voltage (no-load) between Pin 11 and Pin 13 is approximately 8 V.

Functions with cable break detection activated

Output is deactivated via a switch. No current or voltage signal

Red LED flashes

An alarm switching output is activated (closer), Cable breakage ON: 30 Ω
 Cable breakage OFF: ∞
 Capacity max. 30 mA or ±14 V

TECHNICAL DRAWING

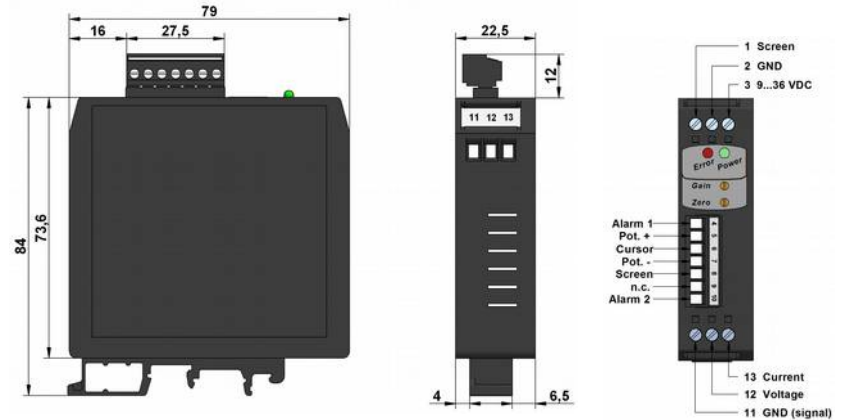

Setting the offset (zero) and gain:

Always install the potentiometer and the cables first, then set zero and gain.

Output signal 0...10 V, 4...20 mA:

1. Move the potentiometer to the start of the measuring range.
2. Offset: Adjust the front Zero potentiometer to 4.000 mA (for 4...20 mA) or 0.000 V (for 0...10 V) output signal.
3. Move the potentiometer to the end of the measuring range.
4. Set gain: Adjust the Gain potentiometer to 20.000 mA or 10.000 V output signal.
5. Check the output signal again at the beginning and the end of the measuring range. If there are minor deviations, please repeat steps 2 to 4.

Output signal 0...5 V: Same procedure as 0...10 V

Output signal ±5 V/ ±10 V:

Move the potentiometer to the center of the measuring range. Set the offset to 0.000 V. Move the potentiometer to the start and end of the measuring range and check if the values are identical (e.g. -10.035 V and +10.035 V). If there is a deviation, adjust with offset potentiometer. Then adjust the gain potentiometer to 5.000 V (-5.000 V) or 10.000 V (-10.000 V).

Signal Inversion:

If an inverted output signal is required (20...4 mA/ 10...0 V/ 5...0 V), please switch terminals 5 and 7 on the conditioner.