

SIGNAL CONDITIONER



PMX-24 Signal Conditioner

Key Features:

- Converts potentiometer signals into analog output signals (e.g. 0...10 V or 4...20 mA)
- With cable break detection and alarm output
- Input: potentiometer 1...20 k Ω
- Differential potentiometer supply
- Configurable output
- Electrically isolated
- High interference resistance
- Low residual ripple
- DIN rail mounting

Content:

Introduction2
Technical Data2
Cable Break Detection3
Electrical Connection3
Settings4

INTRODUCTION

Signal conditioners are used for potentiometers to convert an input signal into a different proportional output signal. These are often standardised values such as 0...10 V or 4...20 mA, needed for ordinary connection to controls. A signal conditioning and an electrical isolation ensures an optimal signal performance.

The PMX-24 offers various current and voltage outputs, e.g. 4...20 mA, 0...10 V, 0...5 V, ± 5 V, ± 10 V, which can be configured easily via DIP switch (switch on the board). The signal output is electrically isolated and characterised by extremely low residual noise, free of any spikes. Concerning the interference, the supply of the potentiometer is realised with a high precise differential voltage reference of ± 5 V, therefore longer cables can be used between the potentiometer and conditioner and signal interference by external system parts are minimised.

TECHNICAL DATA

PMX-24

Output	4...20 mA, 0...10 V, 0...5 V, ± 10 V, ± 5 V, adjustable via DIP switch, electrically isolated, 4 wire technology
Input	Potentiometer with 1...20 k Ω
Supply	9...36 VDC
Max. supply current	30 mA, max. 44 mA (with current output in use)
Max. shunt current output	< 300 Ω
Dynamic	300 Hz (-3 dB) active 6-pole Bessel filter
Noise	< 1 mV _{rms}
Reverse voltage protection	yes, infinite
Short-circuit proof	yes, permanently short-circuit-proof
Working temperature	-40...85 °C
Temperature coefficient < 15°C	0.00032 %/K
Temperature coefficient > 15°C	0.00005 %/K
Power-on drift	0.0025% of FS without warming up
Connection technology	4 wire technology
Protection class	IP30 (EN60529)

Circuit diagram

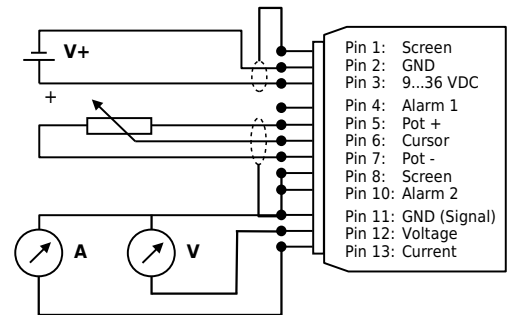

Note:

GND signal and GND can be connected if 3 wire technology is used.

Pin 1 and Pin 8 are internally connected.

!! The PMX is a live power source !!

The open circuit voltage (no-load) between Pin 11 and Pin 13 is approximately 8 V.

TECHNICAL DRAWING

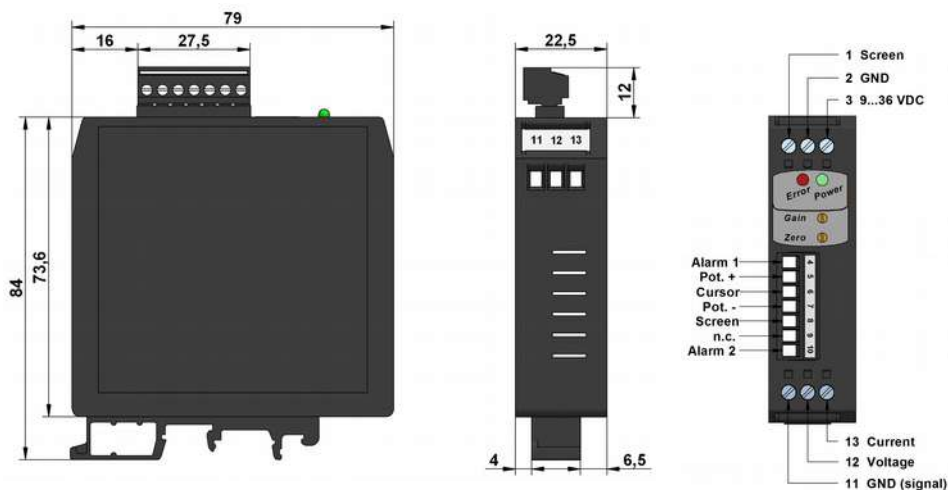

CABLE BREAK DETECTION

In case of a cable break between the sensor and transducer, there is no signal at the electronics input. Conventional devices would detect this as the cursor signal in accordance with the initial position of the potentiometer, where the cursor signal is 0 V. For an analog output of 4...20 mA this corresponds to 4 mA, for bipolar voltage outputs of ± 10 V this corresponds to -10 V, ± 5 V output thus -5 V, etc.

A detected cable break activates the following functions:

1. A switch fully disconnects the outputs and no current or voltage signal is applied to the output.
2. A red ERROR LED on the front of the housing flashes.
3. An alarm switching output is activated (closer), allowing additional actions to be controlled, like an acoustic signal or an emergency shut-off.

The cable break detection is activated when the sensor cable (or at least the supply lines of the potentiometer) is completely cut (a partial break of the wiper connection only will not activate this function). The cable break detection works for potentiometers up to a max. resistance of 20 kOhm.

Functions with cable break detection activated		
Output is deactivated via a switch. No current or voltage signal	Red LED flashes	An alarm switching output is activated (closer), Cable breakage ON: 30 Ω Cable breakage OFF: ∞ Capacity max. 30 mA or ± 14 V

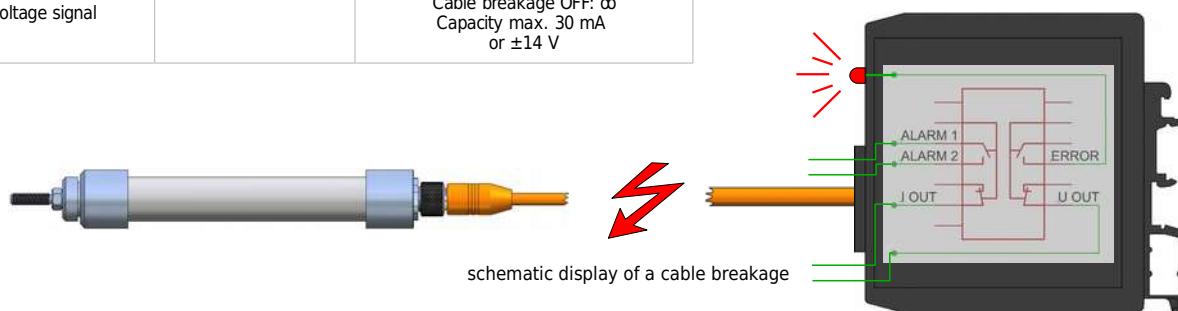

ELEKTRICAL CONNECTION

The housing of the conditioner can be opened by sliding off the cover at the indicated locations. Tools are not required.



After removing the protective foil, the DIP switches on the top of the board can be set to the desired output signal.



on
↑
off

OUT	switch setting
420mA	1 1 0
10V	1 1 0
5V	1 1 1
± 10 V	0 0 0
± 5 V	0 1 0

OUT	Switch Setting		
420 mA	1	1	0
10 V	1	1	0
5 V	1	1	1
± 10 V	0	0	0
± 5 V	0	1	0

SETTINGS

Setting the Offset (zero) and gain:

Please note, when using long lines between the potentiometer and conditioner the zero point and gain may change. Install the potentiometer with the required cable length and then set the zero point and gain. We recommend the following procedure:

1. Move the potentiometer to the start of the measuring range.
2. Offset: Adjust the front Zero potentiometer to 4.000 mA (for 4...20 mA) or 0.000 V (for 0...10 V) output signal.
3. Move the potentiometer to the end of the measuring range.
4. Set gain: Adjust the Gain potentiometer to 20.000 mA or 10.000 V output signal.
5. Check the output signal again at the beginning and the end of the measuring range. If there are minor deviations, please repeat steps 2 to 4.



Output signal 0...5 V: Same procedure as 0...10 V

Output signal ± 5 V/ ± 10 V: Move the potentiometer to the centre of the measuring range. Set the offset to 0.000 V. Move the potentiometer to the start and end of the measuring range and check if the values are identical (e.g. -10.035 V and +10.035 V). If not, adjust with offset potentiometer. Then adjust the gain potentiometer to 5.000 V (-5.000 V) or 10.000 V (-10.000 V).

Signal Inversion:

If an inverted output signal is required (20...4 mA/ 10...0 V/ 5...0 V), please switch terminals 5 and 7 on the conditioner.

Subject to change without prior notice.

WayCon Positionsmesstechnik GmbH

email: info@waycon.de
internet: www.waycon.de

Head Office

Mehlbeerenstr. 4
82024 Taufkirchen
Tel. +49 (0)89 67 97 13-0
Fax +49 (0)89 67 97 13-250

Office Köln

Auf der Pehle 1
50321 Brühl
Tel. +49 (0)2232 56 79 44
Fax +49 (0)2232 56 79 45